

Thermal spray equipment guide

Issue 15 – May 2022

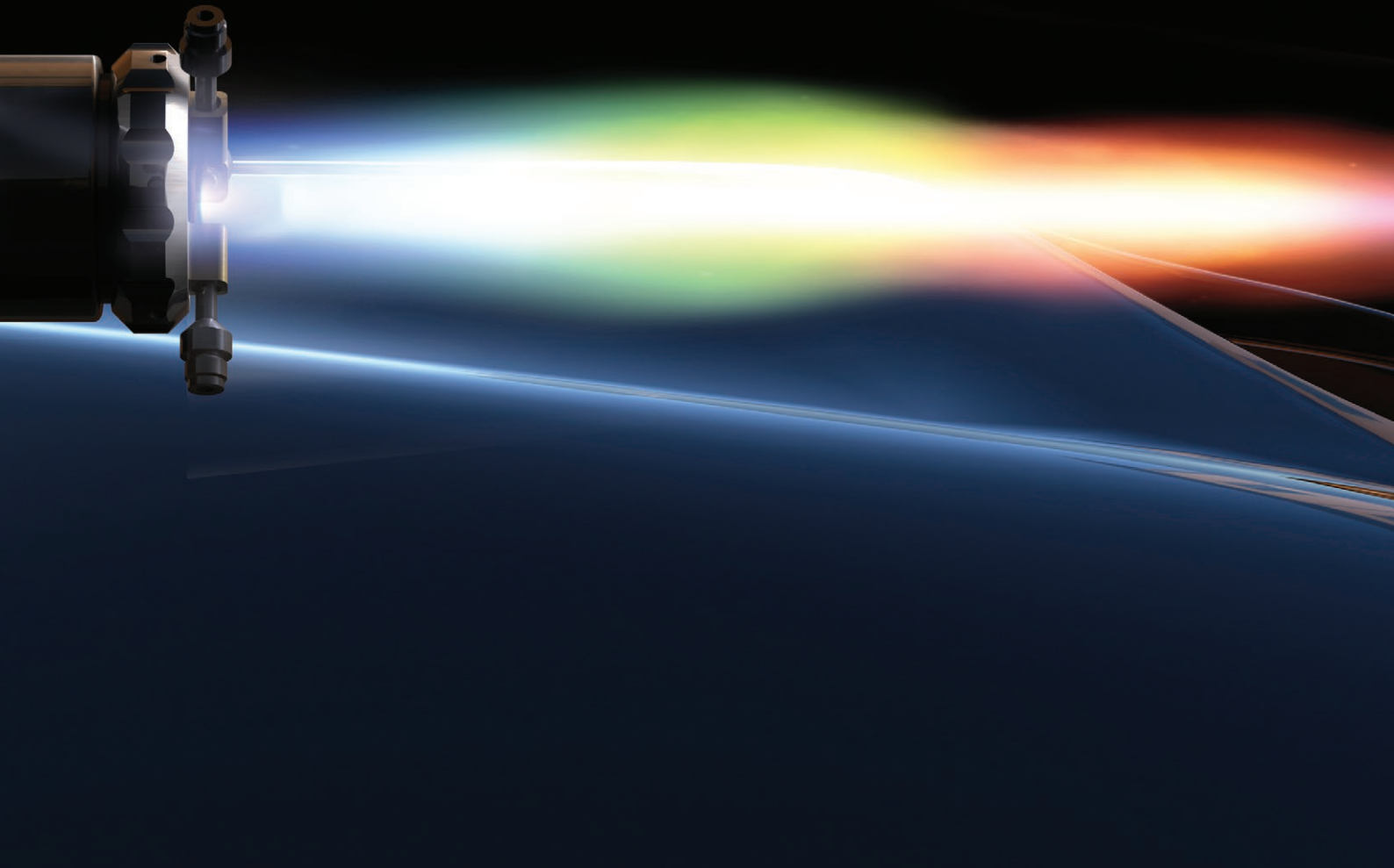

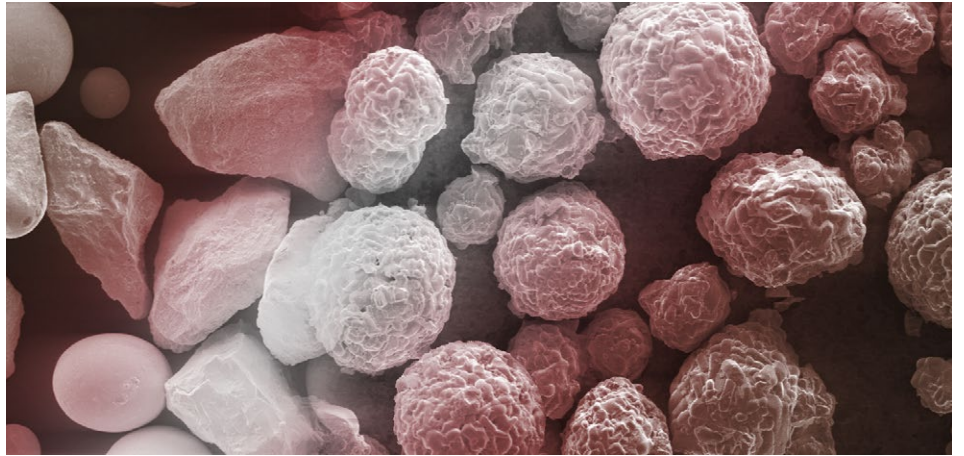

Optimum materials...



Innovative technology...

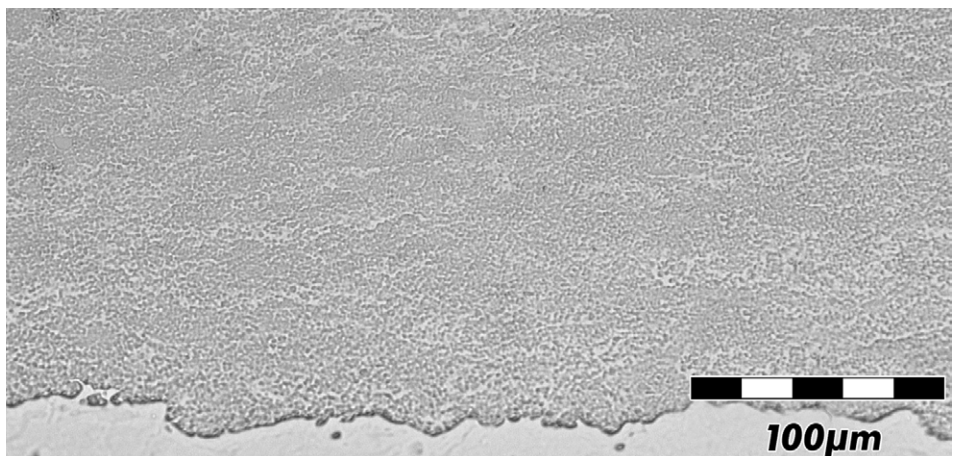

Perfect coatings...

Content

Introduction	4
Thermal spray equipment	4
Spray processes.....	5
Arc processes	5
Combustion processes.....	6
Core components – Plasma	7
Core components – HVOF Gas Fuel.....	11
Core components – HVOF Liquid Fuel.....	14
Core components – Combustion Wire	15
Core components – Combustion Powder.....	17
Core components – Electric Arc	20
Core components – ChamPro™	23
Handling components	24
Peripheral components.....	26
Examples of thermal spray coating systems – Plasma	27
Examples of thermal spray coating systems – HVOF	29
Examples of thermal spray coating systems – Combustion Powder and Combustion Wire.....	31
Examples of thermal spray coating systems – Electric Arc	33
Examples of thermal spray coating systems – ChamPro™	35

Please note:

Throughout this brochure, gray labels indicate non-CE components

Introduction

Thermal spray equipment

Only Oerlikon Metco can offer equipment solutions for all thermal spray processes. And with such a broad selection, we have just what you need for your application. Proven and reliable, Oerlikon Metco has the largest base of installed equipment around the world.

Our focus is on our customer's specific need. Through on-site analysis and customer consultation, our Engineering teams design coating application systems that combine advanced technologies with the broadest line of thermal spray coating products available; that includes advanced robotics and microprocessor controls. The result is the most productive and cost-effective solution for virtually any coating application and budget.

Thermal spray systems are self-contained manufacturing facilities that can be designed for use as individual production units or for integration into manufacturing lines. The subcomponents of a thermal spray system are:

Core components

Core elements are required for all thermal spray solutions. These include the coating material to be applied, a material feed delivery system, the atmospheric plasma spray gun to apply the coating material and propel it to the workpiece, and a control system that accurately controls the processing media and utilities. Depending on the spray process used, a power supply that

converts AC power to DC power may be required. Some thermal spray processes require a heat exchanger to cool the spray gun; other spray processes may require heaters.

Handling components

Handling equipment precisely controls the movement of the spray gun and workpiece, and their relative position to one another.

Peripheral components

The peripheral components can be divided into four categories: Safety components like gas monitoring and warning devices; environmental components like a soundproof cabin, as well as an air filter and exhaust system to protect both personnel and the environment; quality components such as spray plume monitoring and diagnostics for the most advanced process control; and productivity components like software packages for workpiece management, parameter reporting and many others.

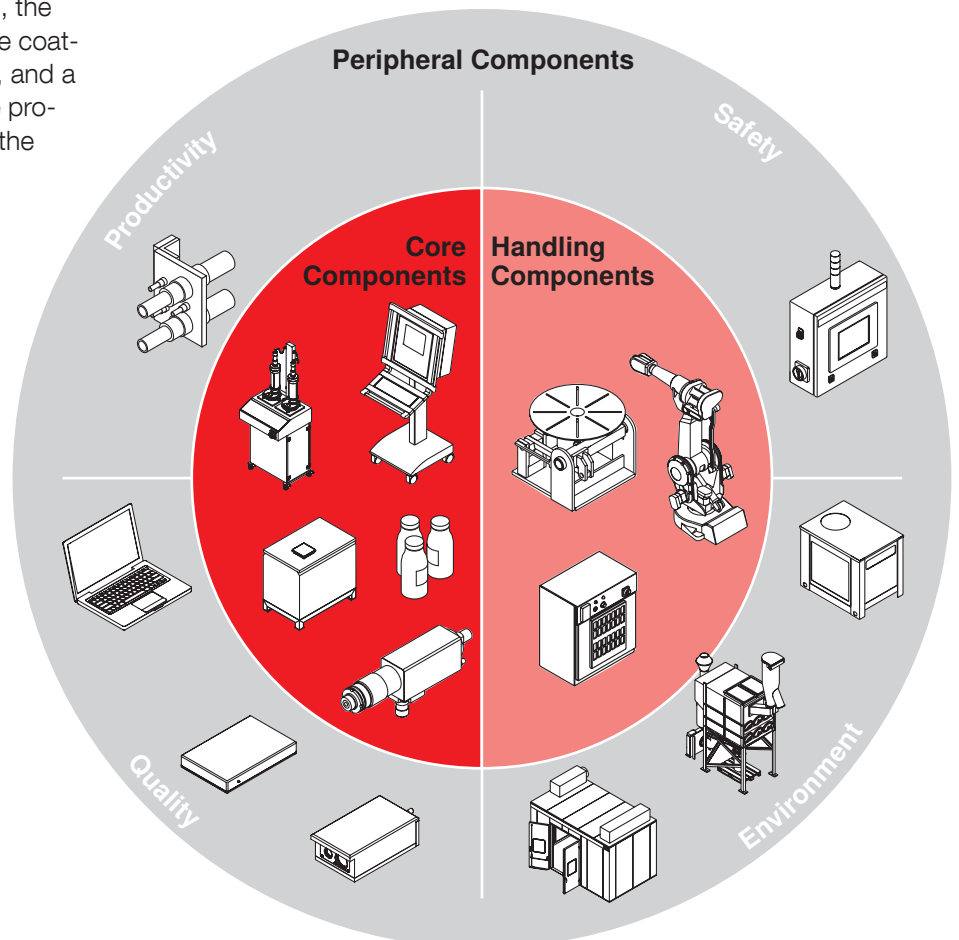

Introduction

Spray processes

Oerlikon Metco's comprehensive portfolio of equipment assures we can deliver systems for every thermal spray application and budget requirement.

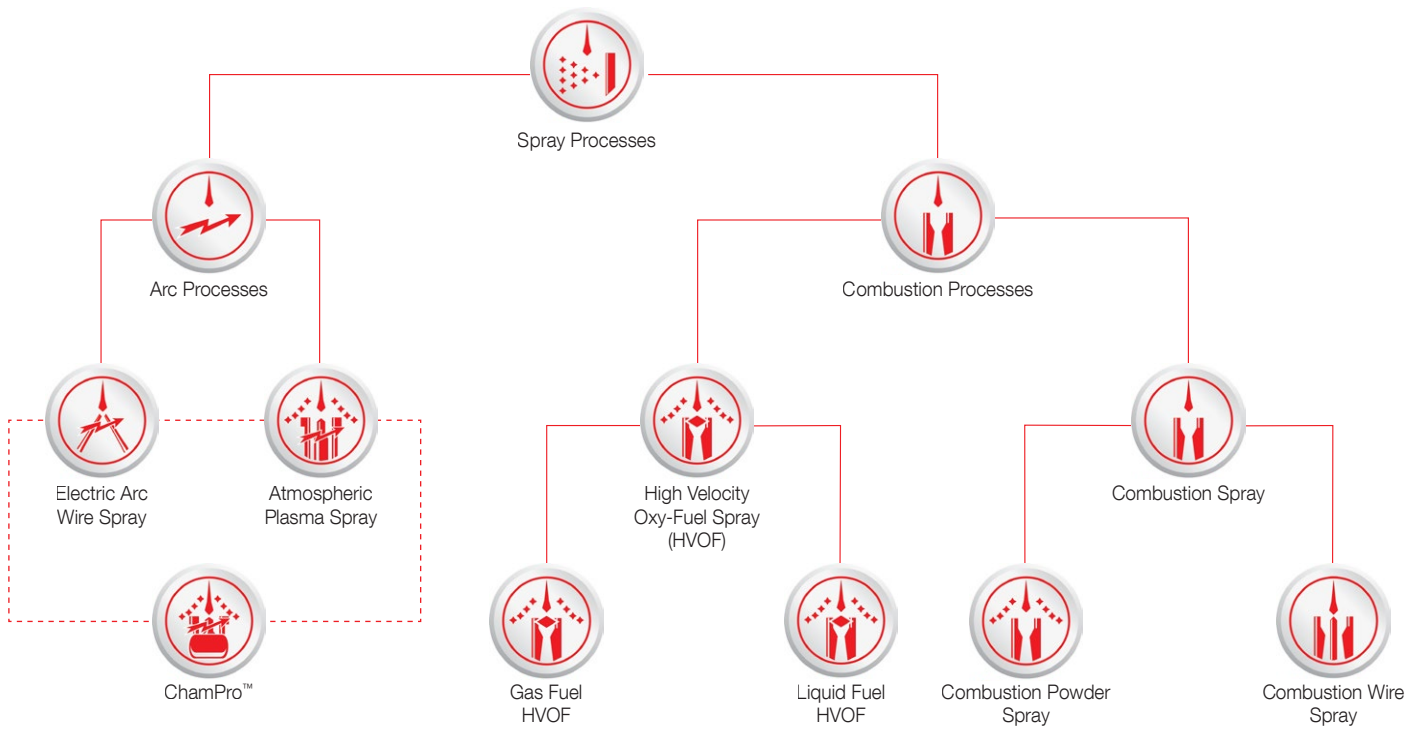

Arc processes

Electric arc wire spray

Electric arc wire spray uses two electrically charged feedstock wires, of opposite polarity, that are brought together at a controlled rate to form an arc. This arc melts the wire feedstock and an air stream propels the molten material to the substrate. Electric arc wire is commonly used to apply bond coat materials, salvage and restoration coatings and a wide range of corrosion coatings on large structures. As the coolest of all thermal spray processes, it can be used to coat many substrates, including metals and plastics.

Atmospheric plasma spray

Atmospheric plasma spray is the most versatile of all thermal spray processes. Using an electric arc to ionize flowing process gases, the hot gas stream can be controlled to melt a very wide range of powder feedstock materials to apply high-quality coatings of metals, metallic alloys, carbides, cermets and oxide ceramics. Atmospheric plasma spray coatings are used for many different applications, just a few of which include bond coats, corrosion coatings for many

different service environments and temperatures, wear coatings, restoration coatings, and thermal barrier materials.

ChamPro™ controlled atmosphere spray

ChamPro refers to plasma spray or electric arc wire spray coatings applied in a chamber at low pressure or near vacuum conditions. ChamPro processes apply superior coatings characterized by high densities or very controlled porosities with extremely low contamination. Systems can be designed for many applications, including the application of refractory metals, thin layers and ceramic structures that cannot be achieved using any other thermal spray process.

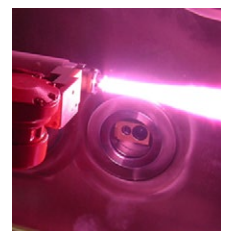

Combustion processes

High Velocity Oxy-Fuel (HVOF) spray

HVOF uses high-pressure combustion as the heat source to create a high-velocity gas stream that both melts and propels a powder feedstock material to the substrate. HVOF coatings generally exhibit fine homogeneous microstructures, low in oxide and porosity content, that are tenaciously bonded to the substrate.

Gas fuel HVOF

Uses gases such as propane, propylene, hydrogen or methane (natural gas) as the fuel source.

Liquid fuel HVOF

Uses kerosene as the fuel source.

Combustion spray

As the name implies, combustion spray uses the combustion of a fuel gas and oxygen to create a heat source, but at lower pressures than HVOF. Combustion spray is an economical choice for the application of quality coatings.

Combustion powder spray

Uses metals, metallic alloys or fine ceramics as the feed stock material in powder form. It is often the process of choice for the application of certain abrasible coatings, particularly to avoid volatilization of a fugitive phase during the spray process.

Combustion wire spray

Uses metals or metallic alloys as the feedstock material in wire form. It is often used for the application of hard coatings for salvage and restoration and is well-known for the application of corrosion coatings, even on very large structures.

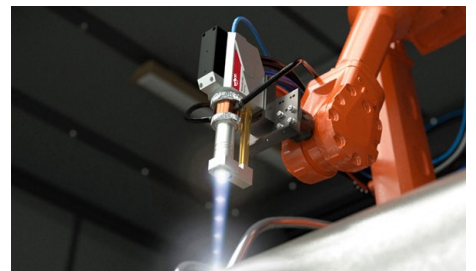

















Thermal spray equipment

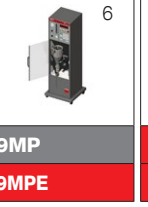

Core components – Plasma

Compatibility chart

Spray Gun	 SM-F1	 SM-F100 CONNEX	 SM-F210	 SM-F220	 SM-F300	
Power output	25 kW	20 kW	15 kW	16 kW	9 kW	
Minimum internal diameter	80 mm (3.1 in)	100 mm (4 in)	60 mm (2.4 in)	85 mm (3.3 in)	40 mm (1.6 in)	
Plasma gas	Ar, H ₂ , He					
Connection angle ³	180°	90° / 180°	90°	180°	180°	
Spray angle ⁴	90°/45°	180°/90°/45°	90°/20°	90°	90°	
Spray length	500 mm (19.6 in)	140/280/560 mm (5.5/11/22 in)	250/450/650 mm (9.8/17.7/25.6 in)	287 mm (11.3 in)	250/450 mm (9.8/17.7 in)	
Controller	 UniCoatPro Plasma		 MultiCoat			
JAMBox	 JAM-1040		 JAM-1020 JAM-1030			
Material Feeder	 Single 240	 5MPE	 9MP 9MPE	 Twin-140 Twin-150	 Single-120-A Twin-120-A Single-220-A	 9MPE-CL20 9MP-CL20
Power Supply	 PTPro-Tower		 PTPro-Low			
Gas Management Center	 GMC Plasma					

¹ Spray length 50 mm (2 in) for external coating applications; limited functionality with UniCoatPro Plasma

² Not compatible with UniCoatPro Plasma

³ Connection angle is the angle between supply hoses and gun axis

⁴ Spray angle is the angle between spray plume and gun axis

⁵ JAM-1020 used with MultiCoat and PT-type power source
JAM-1030 used with MultiCoat and PT3X-type power source





















⁶ Interface box required to operate UniCoatPro Plasma with 5MP and 9MP series feeders; UniCoatPro Plasma provides powder on/off functionality

Thermal spray equipment



Core components – Plasma

Compatibility chart

Spray Gun	 F4MB-XL	 F4MB90-XL		 3MBM		
Power output	55 kW		40kW			
Plasma gas	Ar, H ₂ , He		Ar, H ₂ , He, N ₂			
Connection angle	180°	90°	90°			
Spray angle	0°					
Controller	 9MC	 9MCE	 UniCoatPro Plasma	 MultiCoat		
JAMBox	 9MCD	 JAM-1010	 JAM-1040	 JAM-1020 JAM-1030		
Material Feeder	 Single 240	 9MP 9MPE	 5MPE	 Twin-140 Twin-150	 Single-120-A Twin-120-A Single-220-A	 9MP-CL20 9MPE-CL20
Power Supply	 PTPro-Tower		 PTPro-Low			
Gas Management Center	 GMC Plasma					

¹ 9MC used with 10MR power supply; 9MCE used with PT-1110E power supply

² 9MCD used with 9MC controller

³ JAM-1010 used with 9MCE controller

⁴ JAM-1040 used with UniCoatPro Plasma and PT-type or PT3X power supplies

⁵ JAM-1020 used with MultiCoat and PT-type power supply

JAM-1030 used with MultiCoat and PT3X-type power supply

⁶ 5MPE requires 5MPA Interface for operation with 9MC













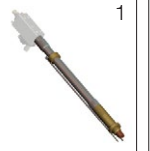
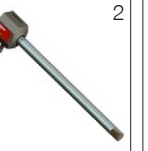

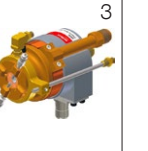





⁷ 9MC and 9MCE can use Twin-150 in stand-alone mode; interface box required to operate 9MP with UniCoatPro Plasma; with all 5MP and 9MP series feeders; UniCoatPro Plasma provides powder on/off functionality

Thermal spray equipment

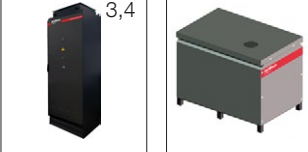

Core components – Plasma

Compatibility chart

Spray Gun	 9MBM	 3MBTD	 7MT-2	 7MST-2	 11MB	 iPro-90	 8MB
Power output	80 kW	40 kW	38 kW; 25 kW	25 kW	30 kW	95 kW	80 kW; 110 kW
Minimum internal diameter	–	102mm (4 in)	75 mm (3 in)	51 mm (2 in)	55 mm (2.2 in)	152 mm (6 in)	–
Plasma gas	Ar, H ₂ , He, N ₂		H ₂ , N ₂ , Ar, H ₂		Ar, H ₂ , He	Ar, H ₂ , He, N ₂	Ar, H ₂ , He, N ₂
Connection angle	180°	180°	180°		180°	90°	180°
Spray angle	0°	90°	65°	45°	90°	90°	0°
Spray length			457 mm (18 in)	406 mm (16 in)	610 mm (24 in)	1010 mm (40 in)	
Controller	 9MC	 9MCE	 UniCoatPro Plasma		 MultiCoat		
JAMBox	 9MCD	 JAM-1010	 JAM-1040	 JAM-1020 JAM-1030			
Material Feeder	 Single 240	 9MP 9MPE	 Twin-140 Twin-150	 5MPE	 Single-120-A Twin-120-A Single-220-A		 9MP-CL20 9MPE-CL20
Power Supply	 PTPro-Tower PTPro-Low						
Gas Management Center	 GMC Plasma						

¹ 7MT-2, 7MST-2 are extensions for the 9MB gun

7MT-2, 7MST-2: N₂, H₂ standard set-up, Ar, H₂ optional

² 11MB requires voltage booster kit when used with 9MCE and PT power supply
11MB requires ignition kit when used with PT3X IPS-500

³ PT-1310E or 10MR-10X used with 9MCE and iPro-90, 8MB

⁴ 9MC used with 10MR power supply; 9MCE used with PT-1110E power supply

⁵ 9MCD used with 9MC controller

⁶ JAM-1010 used with 9MCE controller

⁷ JAM-1040 used with UniCoatPro Plasma and PT-type or PT3X power supplies

⁸ JAM-1020 used with MultiCoat and PT-type power supply
JAM-1030 used with MultiCoat and PT3X-type power supply

⁹ 9MC and 9MCE can use Twin-150 in stand-alone mode only; interface box required to operate UniCoatPro Plasma with 5MP and 9MP series feeders; UniCoatPro Plasma provides powder on/off functionality

















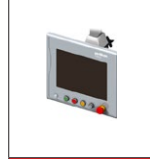
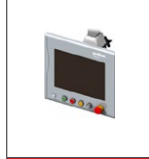

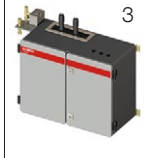
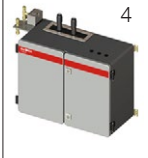
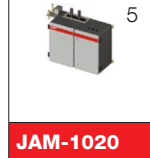
¹⁰ 5MPE requires 5MPA Interface for operation with 9MC

Thermal spray equipment



Core components – Plasma

Compatibility chart

Spray Gun (cascading arc)	 SinplexPro-90		 SinplexPro-180		 TriplexPro-210	
Power output	60 kW				65 to 100 kW	
Plasma gas	Ar, H ₂ , He, N ₂				Ar, H ₂ , He, N ₂	
Connection angle	90°		180°		90°	
Spray angle	0°		0°		0°	
Controller	 9MC	 9MCE	 UniCoatPro Plasma	 MultiCoat	 MultiCoat	
JAMBox	 9MCD	 JAM-1010	 JAM-1040	 JAM-1020 JAM-1030	 JAM-T630	
Material Feeder	 Single 240	 5MPE	 9MP 9MPE	 Twin-140 Twin-150	 Single-120-A Twin-120-A Single-220-A	 9MP-CL20 9MPE-CL20
Power Supply	 PTPro-Tower		 PTPro-Low			
Gas Management Center	 GMC Plasma					

¹ SinplexPro used with 9MC or 9MCE requires CPI-500 Ignition Control Unit
² 9MC used with 10MR power supply; 9MCE used with PT-1110E power supply
³ JAM-1010 used with 9MCE controller; CPI-500 required
⁴ JAM-1040-CPI used with UniCoatPro Plasma and PT-type or PT3X power supply

















⁵ JAM-1020 used with MultiCoat and PT-type power source; CPI-500 required
 JAM-1030 used with MultiCoat and PT3X-type power source only
⁶ JAM-T630 used with MultiCoat and PT3X-type power source
⁷ 9MC and 9MCE can use Twin-150 in stand-alone mode only; interface box required to operate UniCoatPro Plasma with 5MPE and 9MP series feeders; UniCoatPro Plasma provides powder on/off functionality

Thermal spray equipment



Core components – HVOF Gas Fuel

Compatibility chart

Spray Gun (DiamondJet™)						
	 1	 1	 1	 1	 1	 1
Power output	113 kW					
Fuel gases	H ₂	Propane, propylene	Propane	H ₂	Propane, propylene	Methane (natural gas)
Connection angle	180°					
Spray angle	0°					
Controller	 DJF					
JAMBox	 DJFEW 2					
Material Feeder	 5MPE-HP	 9MP-DJ	 9MPE-DJ			

¹ The hand-held DiamondJet “E” series guns are CE conformant only when used with safety handle SH/SHA



















² Required for DiamondJet water-cooled guns

Thermal spray equipment



Core components – HVOF Gas Fuel

Compatibility chart

Spray Gun (DiamondJet™)	 8ADJM	 9ADJM	 1050ADJM	 2600DJM	 2700DJM	 3600DJM
Power output	113 kW					
Minimum internal diameter	-					
Fuel gases	H ₂	Propane, propylene	Propane	H ₂	Methane, ethylene, propane, propylene	H ₂
Connection angle	180°					
Spray angle	0°					
Controller	 DJC	 DJCEH	 MultiCoat			
JAMBox	 DJC 2600 DJCE 2600			 JAM-GF JAM-GLF		
Material Feeder	 5MPE-HP	 9MP-DJ	 9MPE-DJ	 9MPE-DJCL20	 Single-120-H	 Single-220-H
Gas Management Center	 GMC HVOF					

¹ Modified DJC required to run air-cooled guns

² Uses 9MPE-DJ Powder Feeder

³ Required for water-cooled DiamondJet guns









⁴ 5MPE-HP requires 5MPA interface for operation with DJC

Thermal spray equipment



Core components – HVOF Gas Fuel

Compatibility chart

Spray Gun	 1 DJT-2	 1 DJT-2M
Power output	113 kW	
Minimum internal diameter	note 2	
Fuel gases	Uses front gun hardware from customer's existing DiamondJet gun	
Connection angle	180°	
Spray angle ³	90°/60°/45°	
Spray length	700 mm (27.6 in)	
Controller	 DJF	 DJC
JAMBox	 4 DJFEW	 4 DJC 2600
Material Feeder	 5MPE-HP	 9MP-DJ

¹ DJT-2, DJT-2M are extensions for DiamondJet guns

² DJT-2 90°/ DJT-2M 90°: 230 mm (9 in) minimum bore size with air-cooled hardware; 400 mm (16 in) minimum bore size with water-cooled hardware
DJT-2 45° / DJT-2M 45°: 180 mm (7 in) minimum bore size used with air-cooled hardware; 280 mm (11 in) minimum bore size with water-cooled hardware

³ Standard Spray angle for DJT-2 and DJT-2M is 90°. Spray angle of 60° or 45° requires a 60° or 45° spray head, respectively

⁴ Required for water-cooled DiamondJet guns

















⁵ 5MPE-HP requires 5MPA interface for operation with DJC

Thermal spray equipment



Core components – HVOF Liquid Fuel

Compatibility chart

Spray Gun	 1	 2	 2	 1	 2	 2		
	WokaJet-410-Sz	WokaJet-410-S	WokaJet-410	WokaStar-610-Sz	WokaStar-610-S	WokaStar-610		
Power output	293 kW							
Ignition type	Spark plug	Spark plug	Hydrogen	Spark plug	Spark plug	Hydrogen		
Fuel	Kerosene							
Connection angle	90°							
Spray angle	0°							
Controller	 UniCoatPro LF			 MultiCoat				
JAMBox				 JAM-LF JAM-GLF				
Material Feeder	 Single 240	 3 5MPE-HP	 3 9MPE-DJ	 Twin-140-H	 Twin-150	 9MPE-DJ-CL20	 Twin-120-H	 Single-220-H
Gas Management Center				 LMC GLMC				

¹ For use with UniCoatPro LF and newer MultiCoat controllers

² For use with older MultiCoat, UniCoat-GLF or UniCoat-LF controllers











³ In conjunction with 9MPE-DJ and 5MPE-HP powder feeders, UniCoatPro LF controller offers start/stop functionality only

Thermal spray equipment



Core components – Combustion Wire

Compatibility chart

Spray Gun	 1	 1, 2	 1, 2	 1	 1, 3
Power output	30 kW				
Fuel gases	Acetylene, hydrogen, MPS, MAPP, methane, propane				
Connection angle	90°			180°	
Spray angle	0°				
Controller	 5AF	 5GF	 Roadrunner	 6C	 6CEW
Material Feeder	 2W				

¹ Optional gun hardware available for different fuel gases

² High throughput versions available

³ Shown with optional flame detector







⁴ Equipped with combustion wire operation

Thermal spray equipment

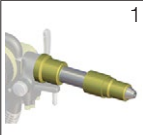

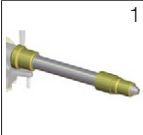
Core components – Combustion Wire

Compatibility chart

Spray Gun	 EGD-K	 5XT-6	 3XT-1	 3XT-2	 3XT-3
Power output	30 kW				
Minimum internal diameter	100 mm (4 in)				
Fuel gases	Acetylene, hydrogen, MPS, MAPP, methane, propane	Acetylene	Acetylene, hydrogen, MPS, MAPP, methane, propane		
Connection angle	180°	Depends on gun hardware			
Spray angle	0°	0°	0° / 45° ²		
Controller	 MultiCoat	Controller depends on gun hardware			
JAMBox	 JAM-F				
Material Feeder	 2W				

¹ 5XT-1 and 3XT-1, -2, -3 are extensions for both 16E type and 5K type guns







² Optional angular air cap required to spray at an angle of 45°

Thermal spray equipment



Core components – Combustion Powder

Compatibility chart

Spray Gun		1	2, 3, 4	2, 3, 4
				
		5P-II	5PT-II-1	5PT-II-2
Power output		35 kW		
Minimum internal diameter		–	168 mm	
Fuel gases		Acetylene, hydrogen		
Connection angle		180°	–	
Spray angle		0°	80° / 0°	
Spray length		–	305 mm (1 ft)	610 mm (2 ft)
Controller				
				
		4AF	4GF	Roadrunner
Material Feeder		built-in		

¹ 5P-II is CE conformant with the SHA safety handle

² 5PT-II-1, -2 are extensions for the 5P-II gun

³ Depending on specific application, Spray angle and material applied



















⁴ Standard Spray angle is 80°; optional hardware required to spray at an angle of 0°

Thermal spray equipment

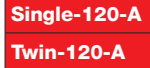

Core components – Combustion Powder

Compatibility chart

Spray Gun	 <p>6P-II-H</p>	 <p>6P-II-HE</p>	 <p>6P-II</p>	 <p>6P-II-A</p>	
Power output	35 kW				
Fuel gases	Acetylene, Hydrogen				
Connection angle	180°				
Spray angle	0°				
Controller	 <p>4AF</p>	 <p>4GF</p>	 <p>6C</p>	 <p>6CE</p>	 <p>MultiCoat</p>
JAMBox	-				 <p>JAM-F</p>
Material Feeder	 <p>9MPE</p>	 <p>9MP</p>	 <p>5MPE</p>	 <p>Single-220-A</p>	 <p>9MPE-CL20</p>
				 <p>Single-120-A</p>	 <p>Twin-120-A</p>
Gas Management Center	-				 <p>GMC Flame</p>

¹ 6P-II-HE is CE conformant only together with the safety handle SHA

² 6P-II is both CE and non-CE conformant



³ JAM-F required for MultiCoat only

Thermal spray equipment



Core components – Combustion Powder

Compatibility chart

Spray Gun	 1, 2, 3 6PT-II-1	 1, 2, 3 6PT-II-2
Power output	35 kW	
Minimum internal diameter	168 mm	
Fuel gases	Acetylene, Hydrogen	
Spray angle	80° / 45°	
Controller	Depends on hand-held or machine-mount configuration	
JAMBox	Depends on hand-held or machine-mount configuration	
Material Feeder	Depends on controller or configuration	
Gas Management Center	Depends on controller	

¹ 6PT-II-1, -2 are extensions for the 6P-II gun

² Minimum internal diameter depends on specific application, Spray angle and material applied

³ Standard spray angle is 80°; optional hardware required 45° spray angle

Thermal spray equipment



Core components – Electric Arc

Compatibility chart

Spray Gun	 PPG	 PPGH	 PPGT-190	 PPGT-290	 PPGT-200
Melting capacity ²	32 kg/h				
Minimum internal diameter	–		90 mm (3.5 in)		
Wire diameters	1.6 to 2.3 mm		1.6 mm		
Connection angle			180°		
Spray angle	0°		90°	90°	0°
Controller/Power Supply	 SmartArc ³				

¹ PPGT-190, -290, -200 are extensions for the PPG type SmartArc guns

² Using zinc wires













³ SmartArc has an integrated material feeder

Thermal spray equipment



Core components – Electric Arc

Compatibility chart

Spray Gun					
					
LD/U3	LD/U2	LD/Schub 5			
Melting capacity ¹	25 to 60 kg/h	20 to 30 kg/h	30 to 35 kg/h		
Wire diameters	2/2.5 mm	1.6 to 2.5 mm	1.6 to 2.5 mm		
Connection angle	180°	90°	180°		
Spray angle	0°	90°	0°		
Controller / Power Supply					
					
ECO ARC 350	ECO ARC 600	FLEXI ARC 200	FLEXI ARC 300	CAP 300	TUBE 300
Material Feeder					
					
Push 4	Push 1	Push 6			

¹ Using zinc wires

² ECO ARC 350 for use with 2.3 mm (11 ga) and 2.5 mm wires only

³ ECO ARC 600 for use with 2.5 mm wires only

⁴ FLEXI ARC 300 can also be used with LD/U3



⁵ For use with FLEXI ARC 300 only

Thermal spray equipment



Core components – Electric Arc

Compatibility chart

Spray Gun	 Extension 300 mm	 Extension 500 mm
Melting capacity	Depends on gun hardware and power supply	
Minimum internal diameter	100 mm (4 in)	
Standard wire diameter	Depends on gun hardware	
Connection angle	180°	
Spray angle	70°	
Spray length	300 mm (11.8 in)	500 mm (19.7 in)
Controller / Power Source	Depends on gun hardware	
Material Feeder	Depends on gun hardware	













¹ These extensions are used with the LD/U2, LD/U3 and LD/Schub 5 guns
 Adapter needed between spray gun and extension
 Customized lengths available on request

Thermal spray equipment



Core components – ChamPro™

Compatibility chart







Spray Gun	 F4-VB	 SinplexPro 03C	 PPG	 PPGT
Power output	45 kW	120 kW	–	
Melting capacity	–		32 kg/h	
Minimum internal diameter	–		70 mm (2.8 in)	
Wire diameters	–		1.6 – 2.3 mm	
Connection angle	180°		–	
Spray angle	0°	0°		90° / 0° ¹
Controller	 MultiCoat		 SmartArc	
JAMBox	 JAM-2030 JAM-3030		–	
Material Feeder	 Single-120-V Twin-120-V		Integrated within gun and controller hardware	
Power Supply	 PTPro-Tower	 PTPro-Low	 SmartArc 350RU	
Gas Management Center	 GMC Plasma		–	

¹ PPGT-200 only

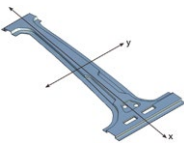
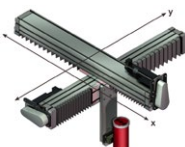
Thermal spray equipment

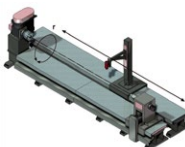
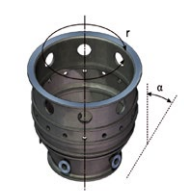
Handling components

Overview

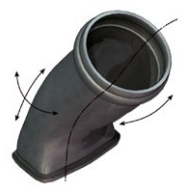
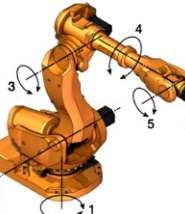



Workpiece geometry	Handling		Oerlikon Metco component		
	Gun manipulator	Workpiece manipulator			
	<p>Flat geometry requires moving the spray gun in two directions</p>	<p>XY CN handling with two axes</p>	<p>None, workpiece fixed</p>		
	<p>For cylindrical workpieces, the gun is moved linearly along the workpiece axis while the workpiece is rotated on a lathe</p>	<p>CN linear handling with one axis</p>	<p>Lathe</p>		<p>Lathe series</p>
	<p>For rotationally symmetrical workpieces, the gun moves in one direction while rotation is accomplished using a turntable. Use of a tilting turntable enables changing the angle of the workpiece relative to the gun</p>	<p>Fixed or linear handling with one axis</p>	<p>Turntable Rotating and tilting table Rotating and tilting table with positionable axes</p>		<p>Robax series turntables UT series tables 9H series turntables</p>
	<p>For workpieces that are not rotationally symmetrical or too large to rotate, the gun can be continuously rotated and also moved in a direction perpendicular to the workpiece</p>	<p>Continuously rotating gun</p>	<p>None, workpiece fixed</p>		<p>Rotaplasma HS-1 Series</p>
	<p>Workpieces with complex geometries require the gun to be manipulated freely in space. Additional workpiece manipulation may also be required</p>	<p>6 axes robot</p>	<p>Depending on the geometry an additional tilting turntable</p>		

Oerlikon Metco can design and seamlessly integrate any type of handling component into a thermal spray coating system—safely and with excellent performance.

Thermal spray equipment

Handling components

Overview

Turntables	 Robax-200	 Robax-1000	 UT-1000	 9HL-1K	 9HLP
Loading weight	113 kg / 440 lb	1000 kg / 2204 lb	1000 kg / 2204 lb	454 kg / 1000 lb	113 kg / 250 lb
Max. rotation	50 to 360 rpm	0.52 to 31.4 rad/s	0.52 to 31.4 rad/s	50 to 360 rpm	50 to 360 rpm
Faceplate diameter	4 DIN 600 mm (23.6 in) 4 DIN 800 mm (31.5 in) 4 DIN 1000 mm (39.5 in)	4 DIN 800 mm (31.5 in) 4 DIN 1000 mm (39.5 in) 6 DIN 1000 mm (39.5 in) 8 DIN 1200 mm (47.25 in)	8 DIN 1100 mm (43.3 in)	4 DIN 610 mm (24 in) 4 DIN 914 mm (36 in)	4 DIN 610 mm (24 in) 4 DIN 914 mm (36 in)
Faceplate tilting	-45° to +90°	-45° to +90°	0°	0 to 90°	0°

Oerlikon Metco standard Robax-series and 9H-series turntables are configured to customer requirements; e.g., automated or manual tilting axes, various load capacities, rotary speeds, tilt ranges and other specialized functionalities.

RotaPlasma™ HS1



Rotation	10 to 800 rpm			
RotaCoupler™/Spray gun	SM-F210-7443	SM-F210-7445	SM-F210-5122	SM-F220-8545
Minimum bore diameter	74 mm (2.9 in)	74 mm (2.9 in)	55 mm (2.0 in)	85 mm (3.3 in)
Typical spray distance	43 mm (1.7 in)	45 mm (1.8 in)	22 mm (0.87 in)	45 mm (1.8 in)
Spray controller	MultiCoat			

Oerlikon Metco spray guns are integrated with the RotaCoupler assembly. Based on your specific spray requirements, Oerlikon Metco Systems Engineering will choose the most suitable unit. Please note that custom shaft lengths are available for deeper bores, if required.

Robots

Upon request, Oerlikon Metco is capable of integrating any type of robot for gun manipulation into a coating system.

Other gun manipulators



Oerlikon Metco offers a wide range of customized gun handling devices to meet customer-specific requirements.

Thermal spray equipment



Peripheral components

Safety components	 <p>GSM-II</p>	 <p>Signal Lamps</p>
--------------------------	--	--

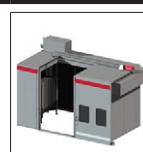
Description	GSM-II monitors potentially dangerous concentrations of flammable or explosive gases and shuts them off before critical levels are reached.	Signal lamps inform and alert the operator acoustically and visually on the state of the system.
-------------	---	--

Environmental control components	 <p>Heat Exchanger</p>	 <p>Filter</p>	 <p>Spray Booth</p>
---	--	--	---

Description	Heat exchangers and water chillers are specifically designed for thermal spray processes and chosen based on cooling capacity required.	Filters and complete exhaust systems protect the operator and the environment from overspray waste. Various options and capacities are available based on spray processes, materials and application rates used.	The spray booth isolates the thermal spray process and protects personnel and the environment from noise, emissions and motion hazards associated with thermal spray processes. Booth design based on processing requirements.
-------------	---	--	--

Quality components	 <p>Accuraspray 4.0</p>	 <p>ScheduleIt</p>	 <p>SelectIt</p>
---------------------------	---	--	--

Description	Accuraspray* provides precise, real-time measurement of the intensity, position and geometry of the thermal spray plume, and measures spray particle temperature and velocity.	MultiCoat software add-on to display the maintenance status of the system components and upcoming maintenance schedules.	MultiCoat software add on that stores all spray parameter and handling routines for a specific workpiece, and creates a complete quality dossier for the workpiece through the collection of all spray processing data.
-------------	--	--	---

Productivity components	 <p>SumIt</p>	 <p>IO Status Page</p>	 <p>QuikSwap</p>
--------------------------------	---	--	--

Description	MultiCoat software add on to monitor and record the usage of all spray processing media and consumables, providing accurate processing costing information.	MultiCoat software add-on to speed up the fault finding process by displaying the input/output ports of the PLC.	QuikSwap greatly reduces the time required for plasma gun changeover.
-------------	---	--	---

¹ For MultiCoat only

Thermal spray equipment



Examples of thermal spray coating systems – Plasma

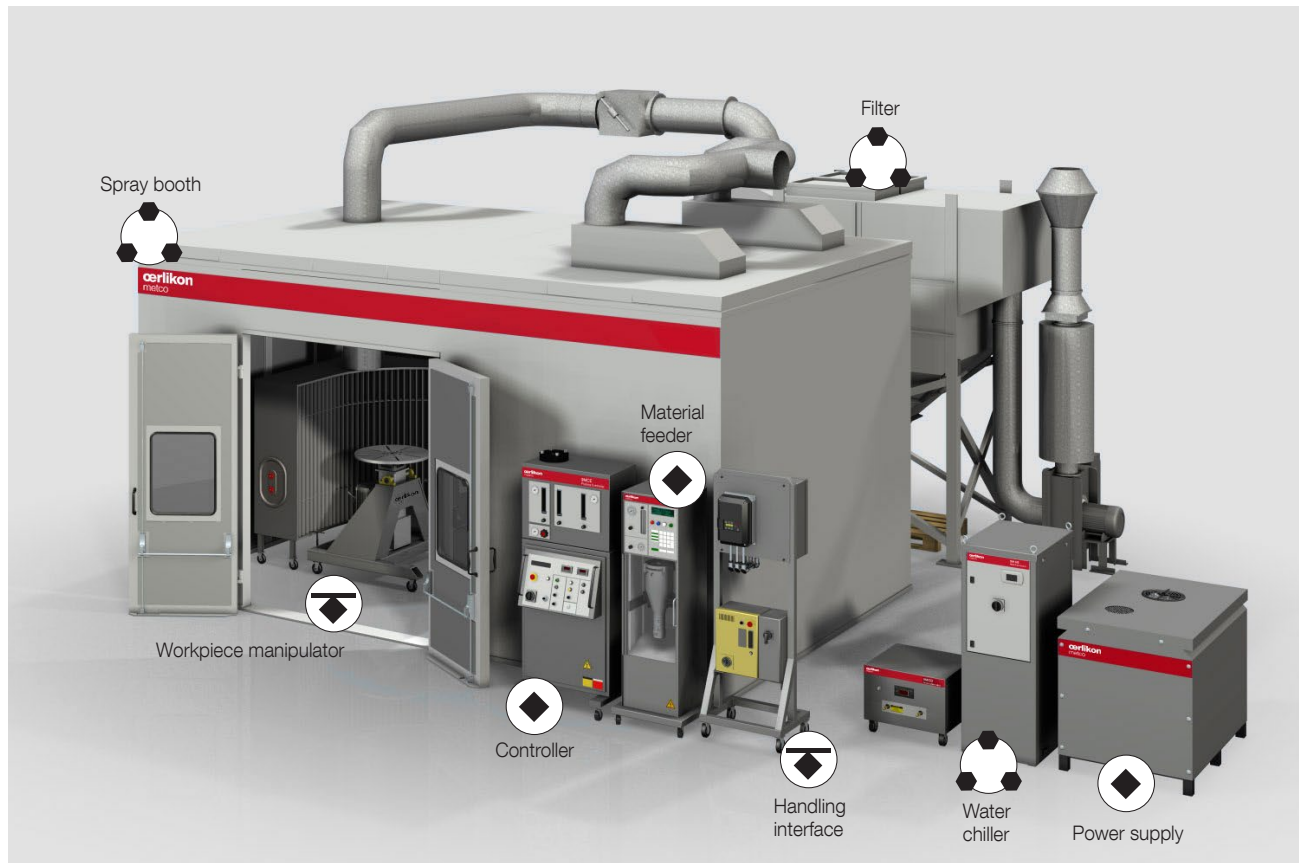
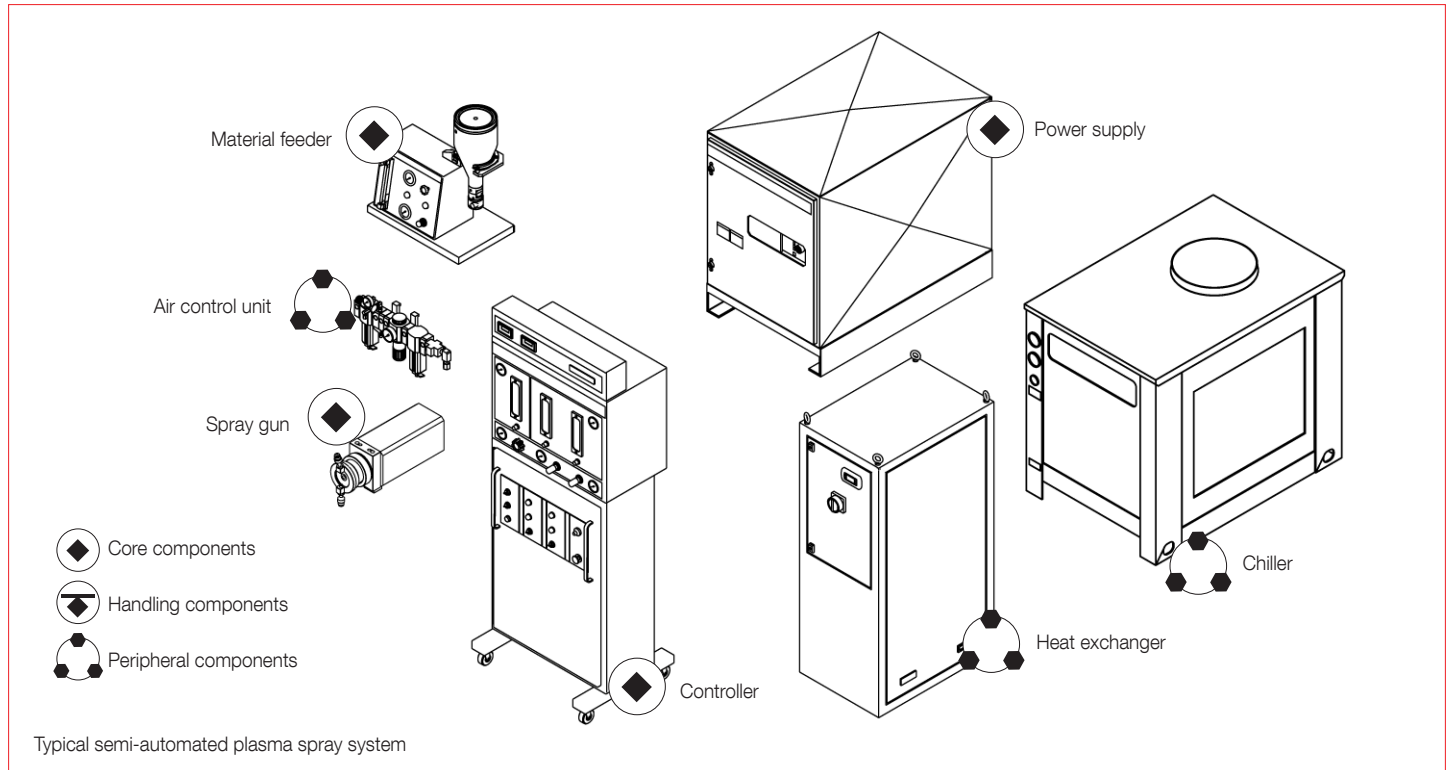

Mid-range plasma spray system with automated handling

Thermal spray equipment



Examples of thermal spray coating systems – Plasma

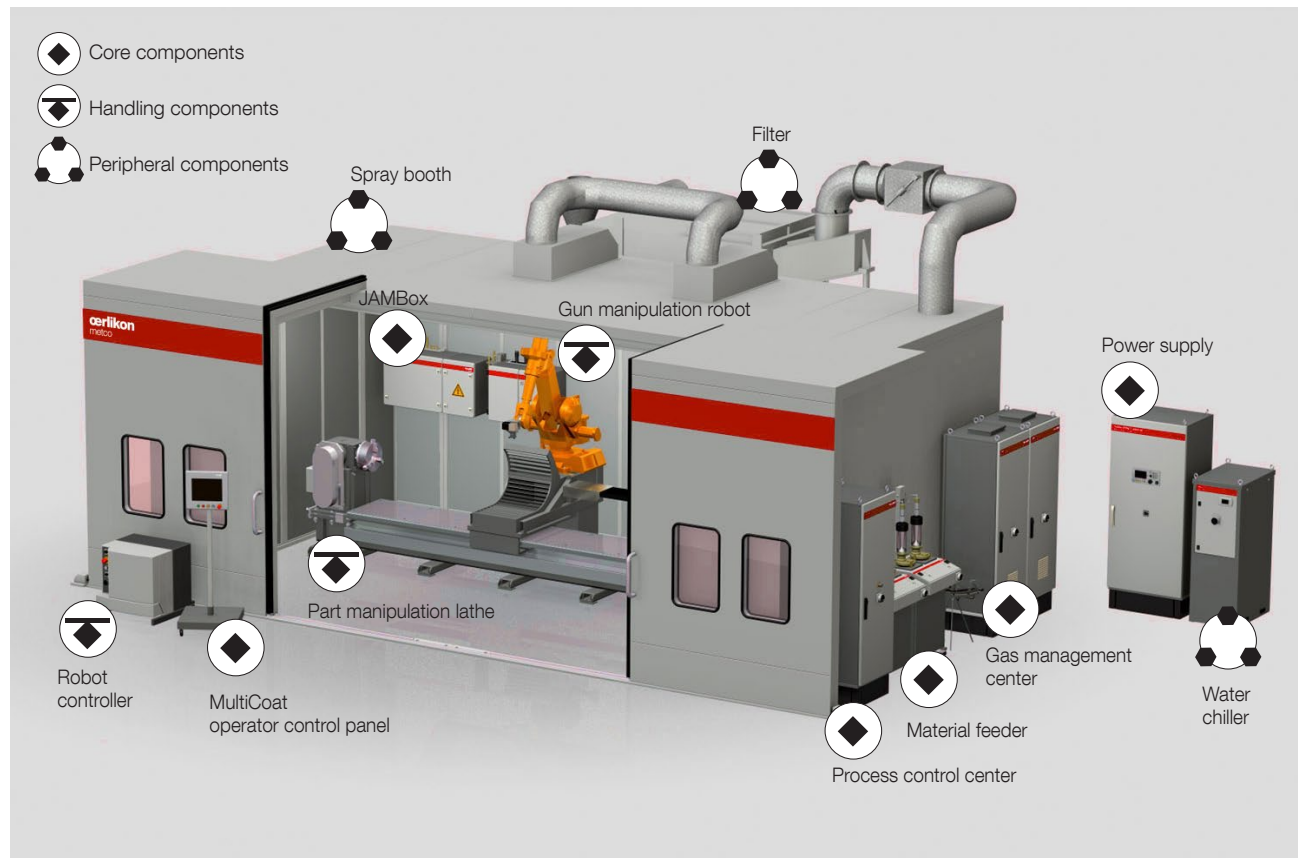

High-end MultiCoat plasma spray system with fully automated handling

Thermal spray equipment



Examples of thermal spray coating systems – HVOF

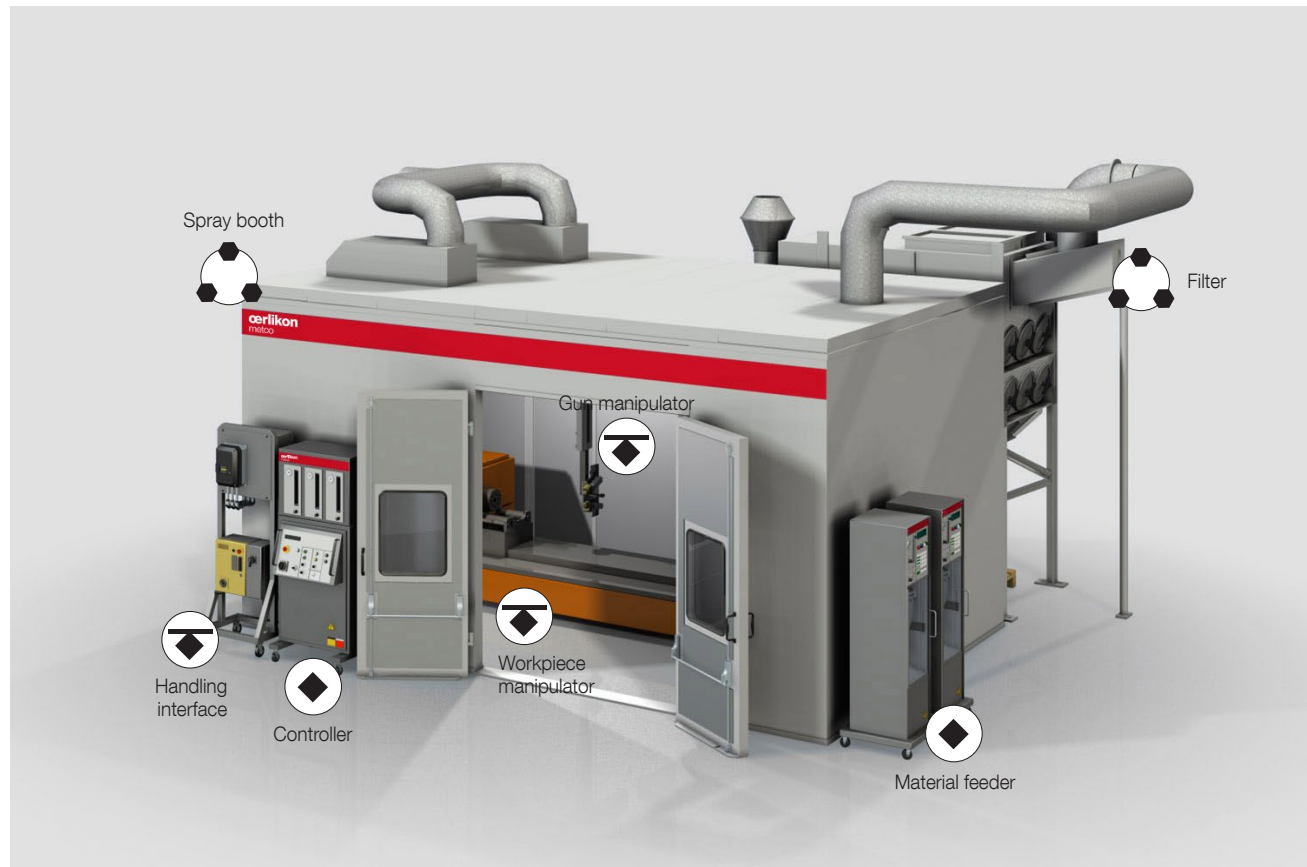
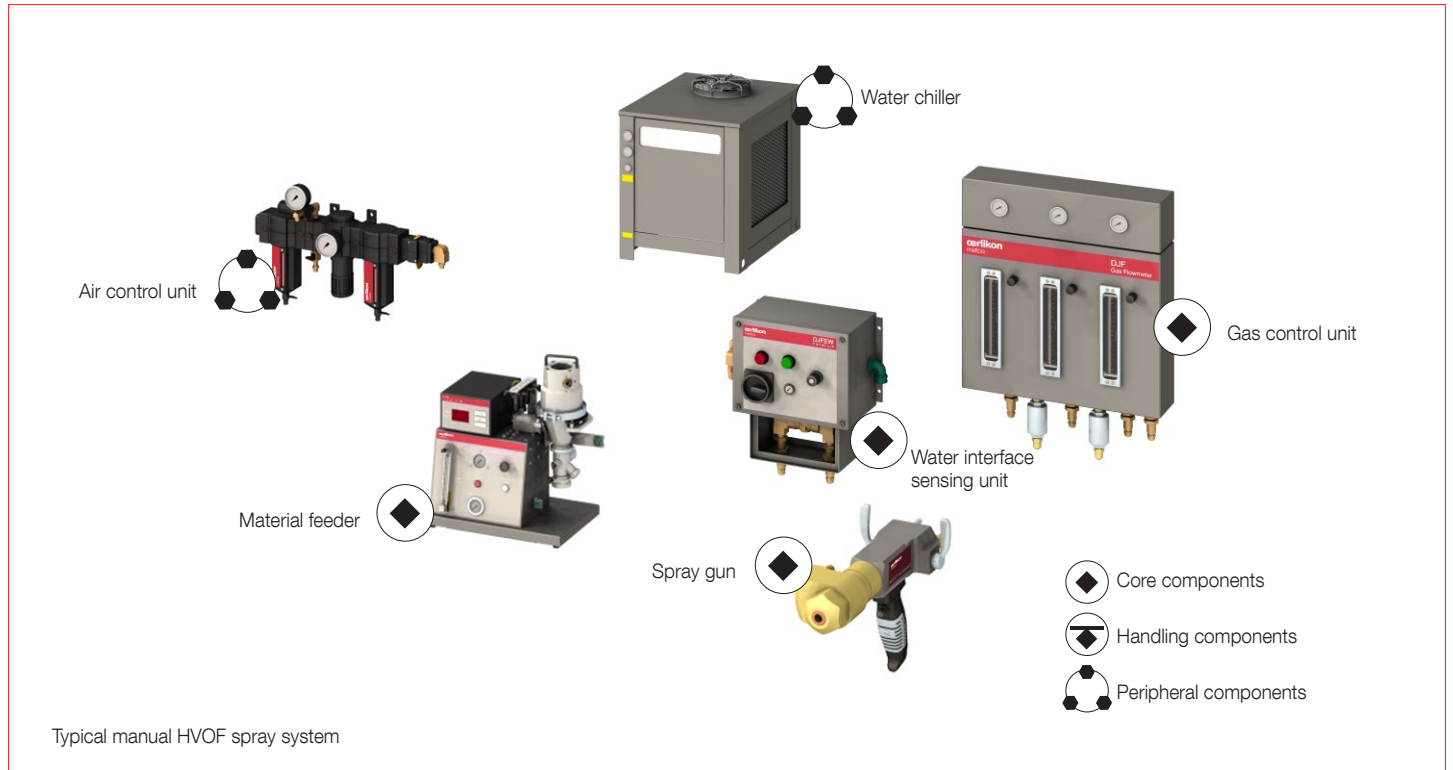

Mid-range HVOF spray system with automated handling

Thermal spray equipment



Examples of thermal spray coating systems – HVOF

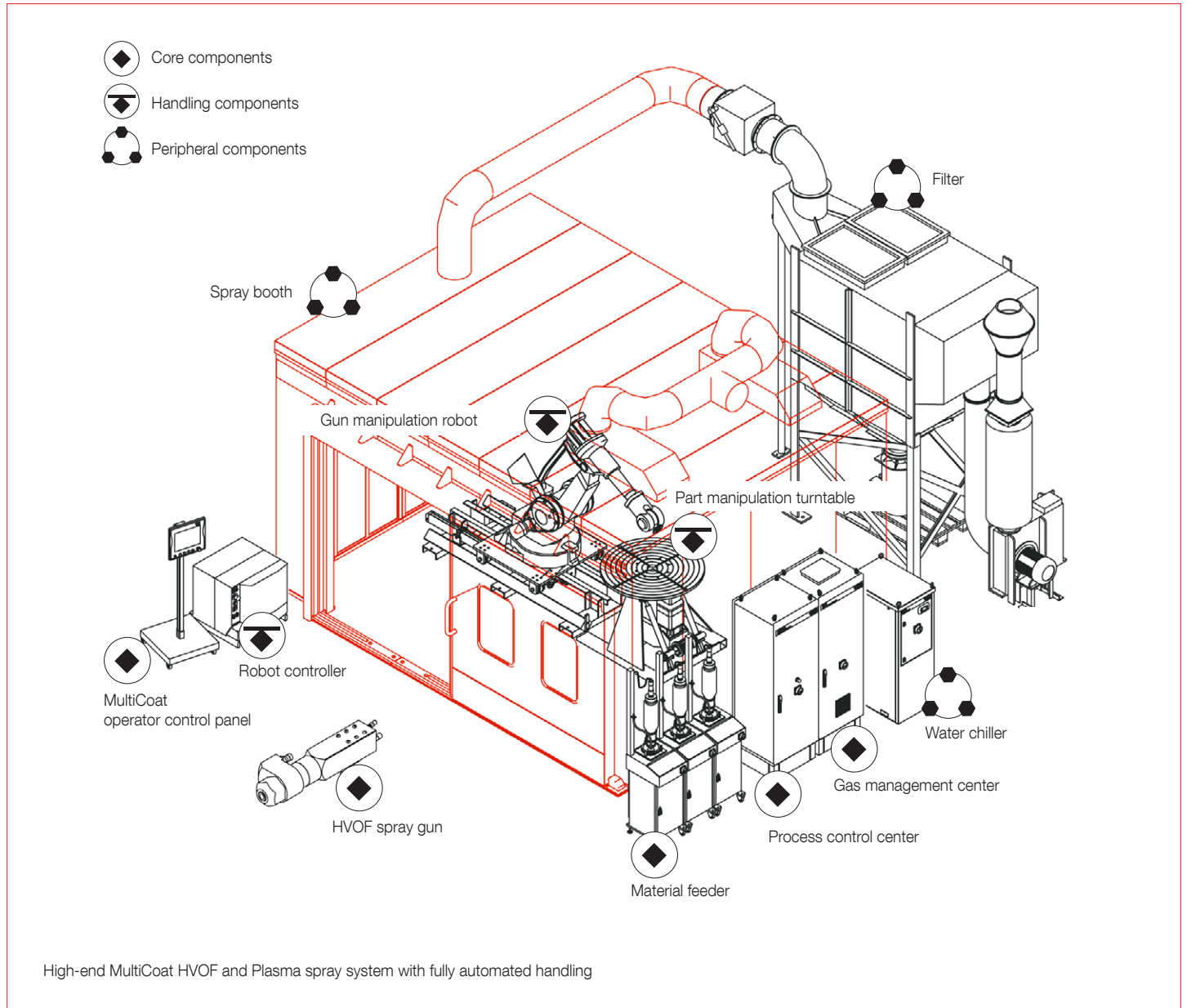

Thermal spray equipment



Combustion Powder



Combustion Wire

Examples of thermal spray coating systems – Combustion Powder and Combustion Wire

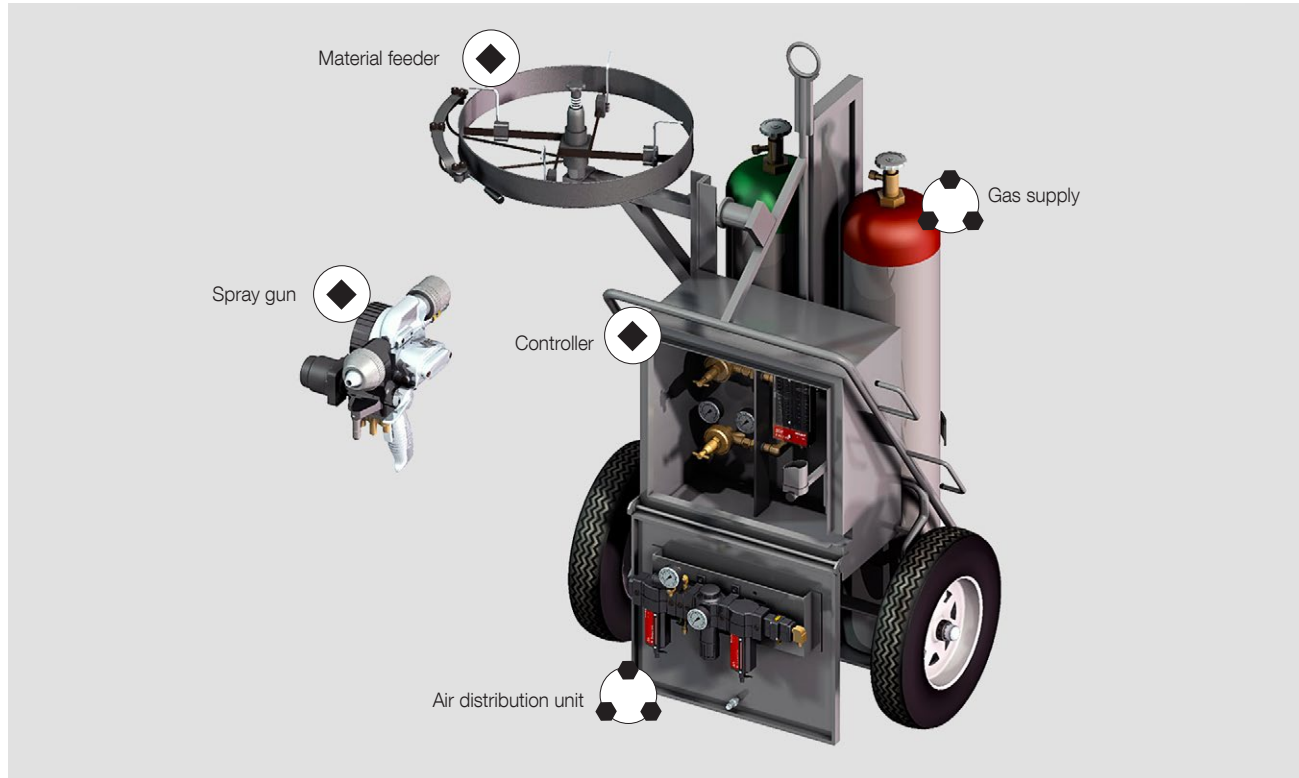

Typical manual Combustion Wire system

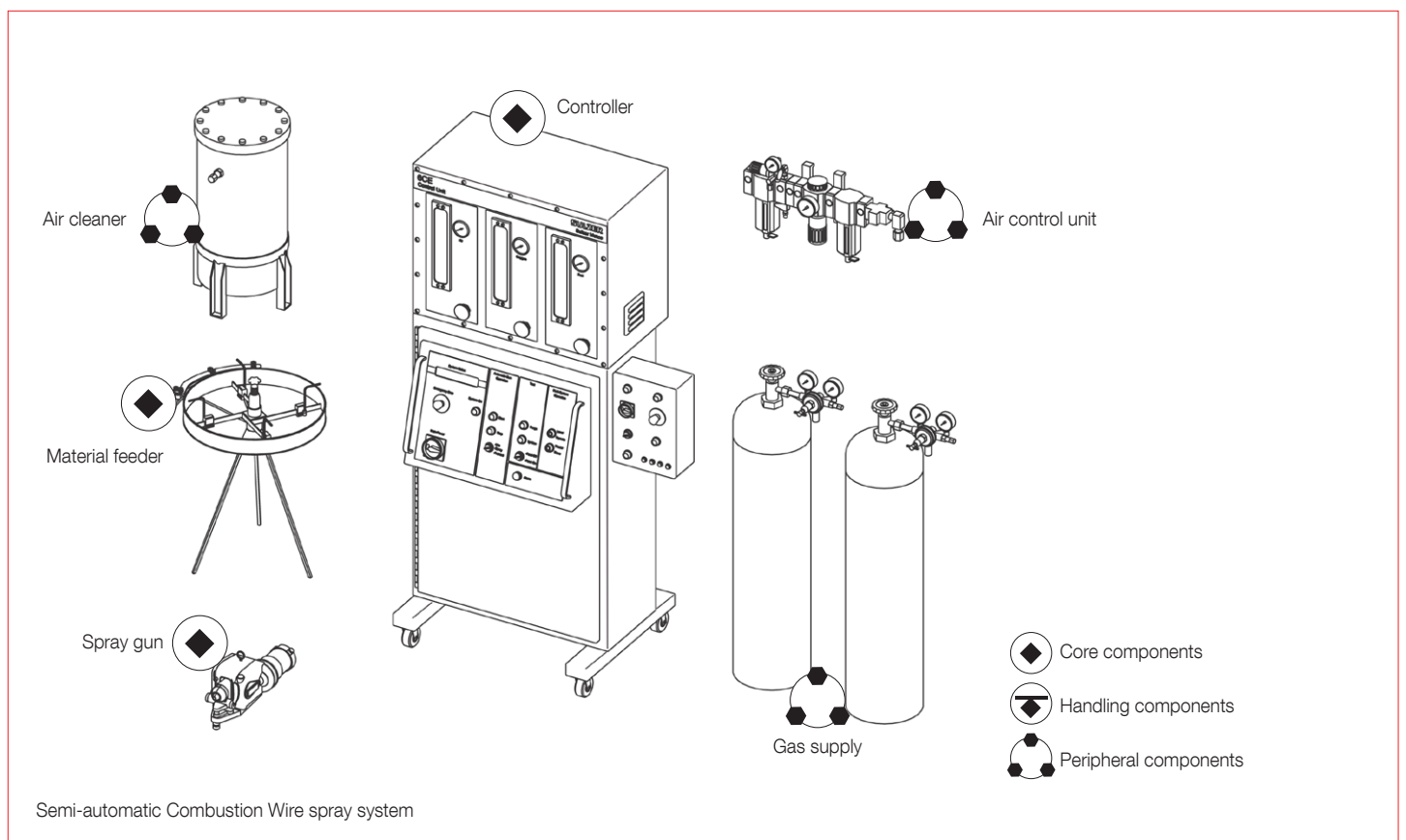

Semi-automatic Combustion Wire spray system

Thermal spray equipment

Examples of thermal spray coating systems – Combustion Powder and Combustion Wire



High-end Combustion Wire spray system with fully automated handling

Thermal spray equipment



Examples of thermal spray coating systems – Electric Arc

- ◆ Core components
- ◀ Handling components
- ⊙ Peripheral components



Typical manual Electric Arc system

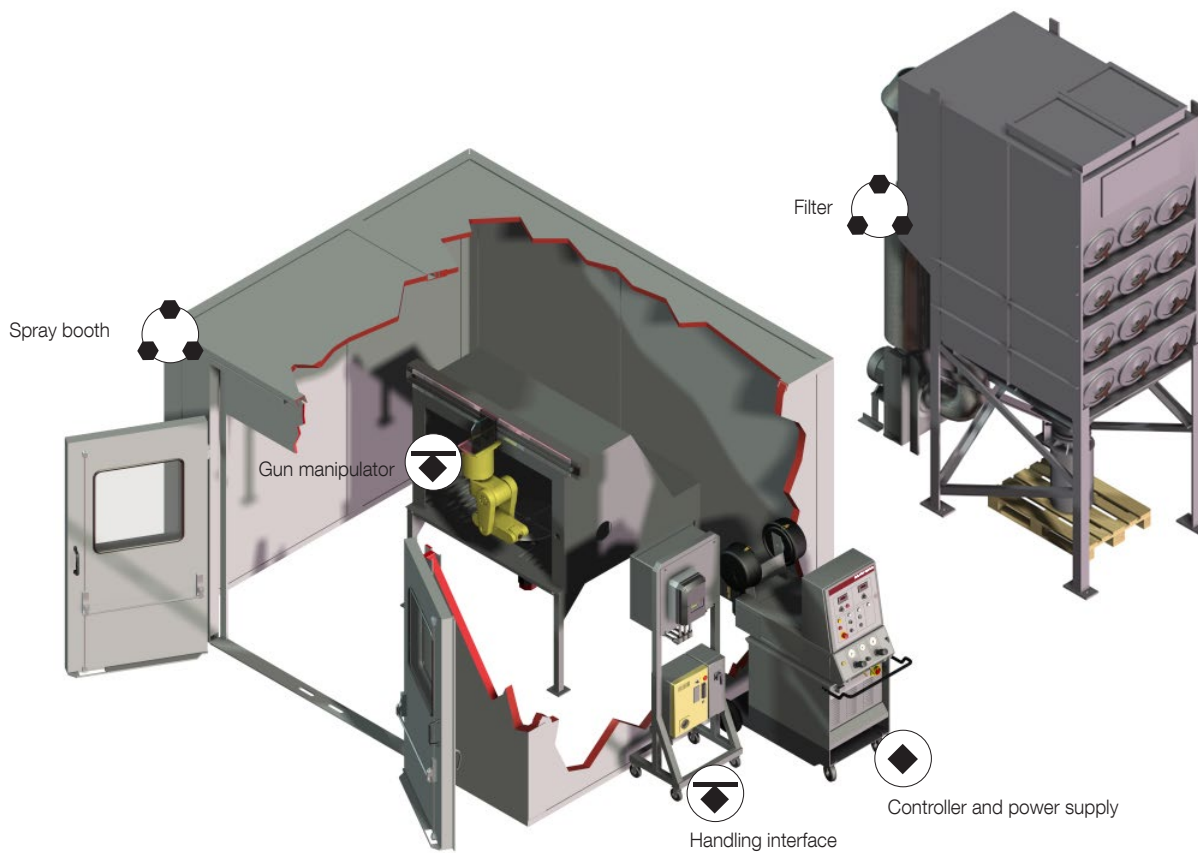

Semi-automatic Electric Arc spray system

Thermal spray equipment



Electric Arc

Examples of thermal spray coating systems – Electric Arc

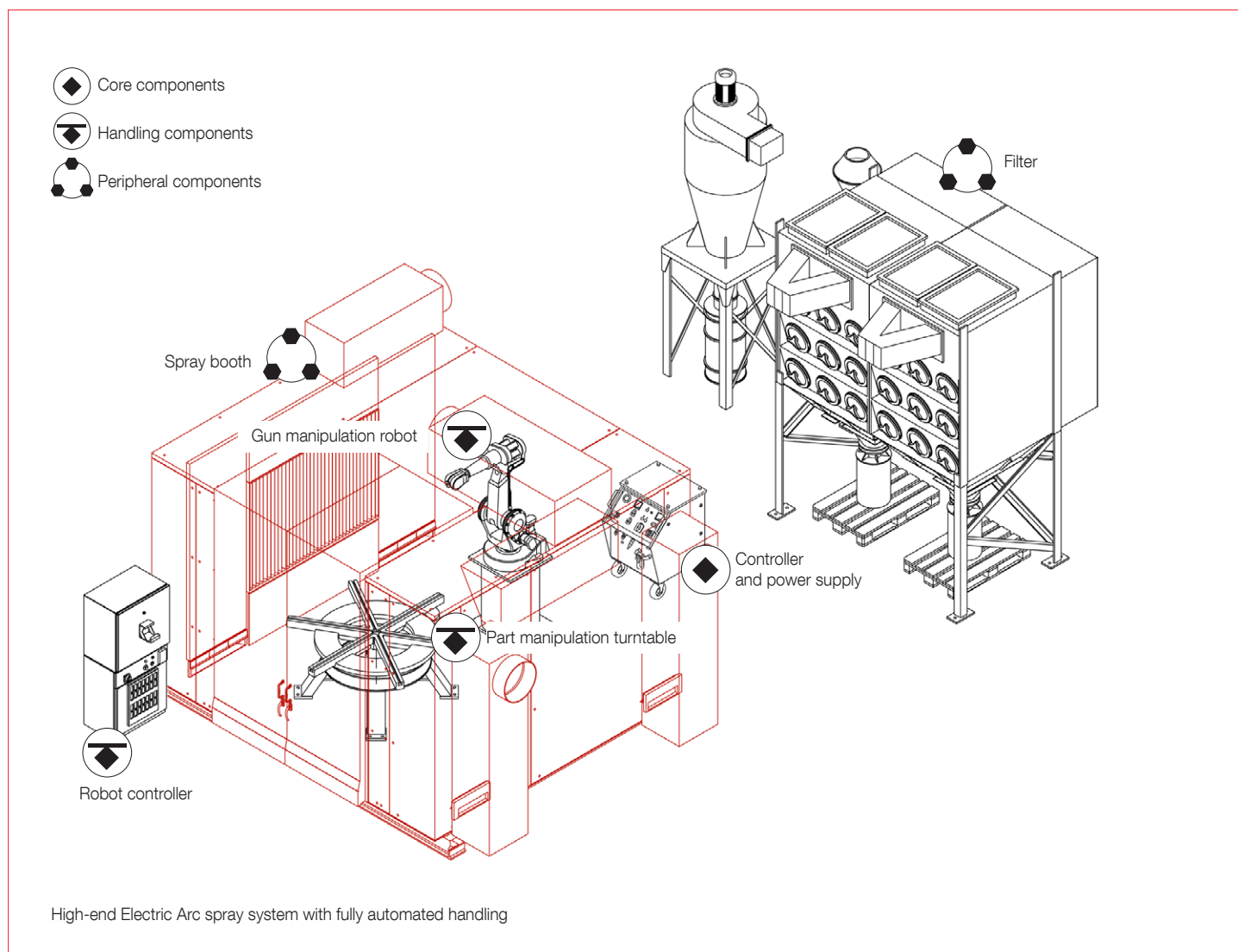

Thermal spray equipment



Examples of thermal spray coating systems – ChamPro™



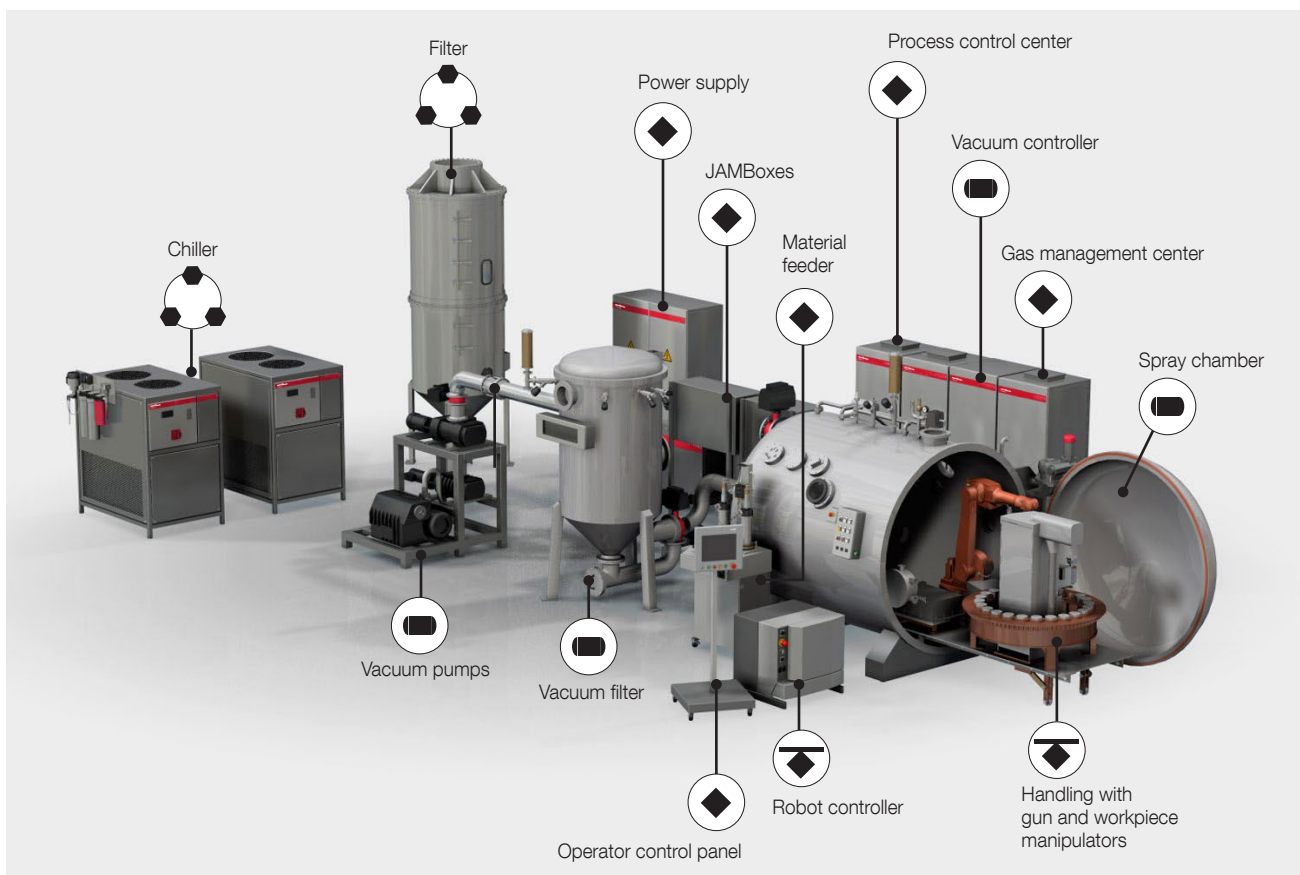

In the ChamPro plasma or wire arc spray systems, the spray process runs under a controlled atmosphere. This environment is chemically inert and at a low pressure condition of approximately 50 mbar. This prevents unwanted oxidation of the spray material.

A ChamPro system typically consists of modified plasma or wire arc system components, equipment needed to create and maintain the controlled atmosphere, and specialized handling and peripheral components. All ChamPro plasma systems can be delivered with reverse transferred-arc functionality used for cleaning parts prior to coating.

ChamPro™ – VPS System



VPS is a batch-processing system. Once a batch of parts has been loaded, the chamber is pumped down and back-filled with argon. The parts are then coated, followed by a cool-down cycle and back-fill with air to ambient pressure. The parts are then unloaded and the cycle is repeated with the next batch of parts.

-  Core components
-  Handling components
-  Peripheral components
-  ChamPro components

Thermal spray equipment



Examples of thermal spray coating systems – ChamPro™

ChamPro™ – SVPS System

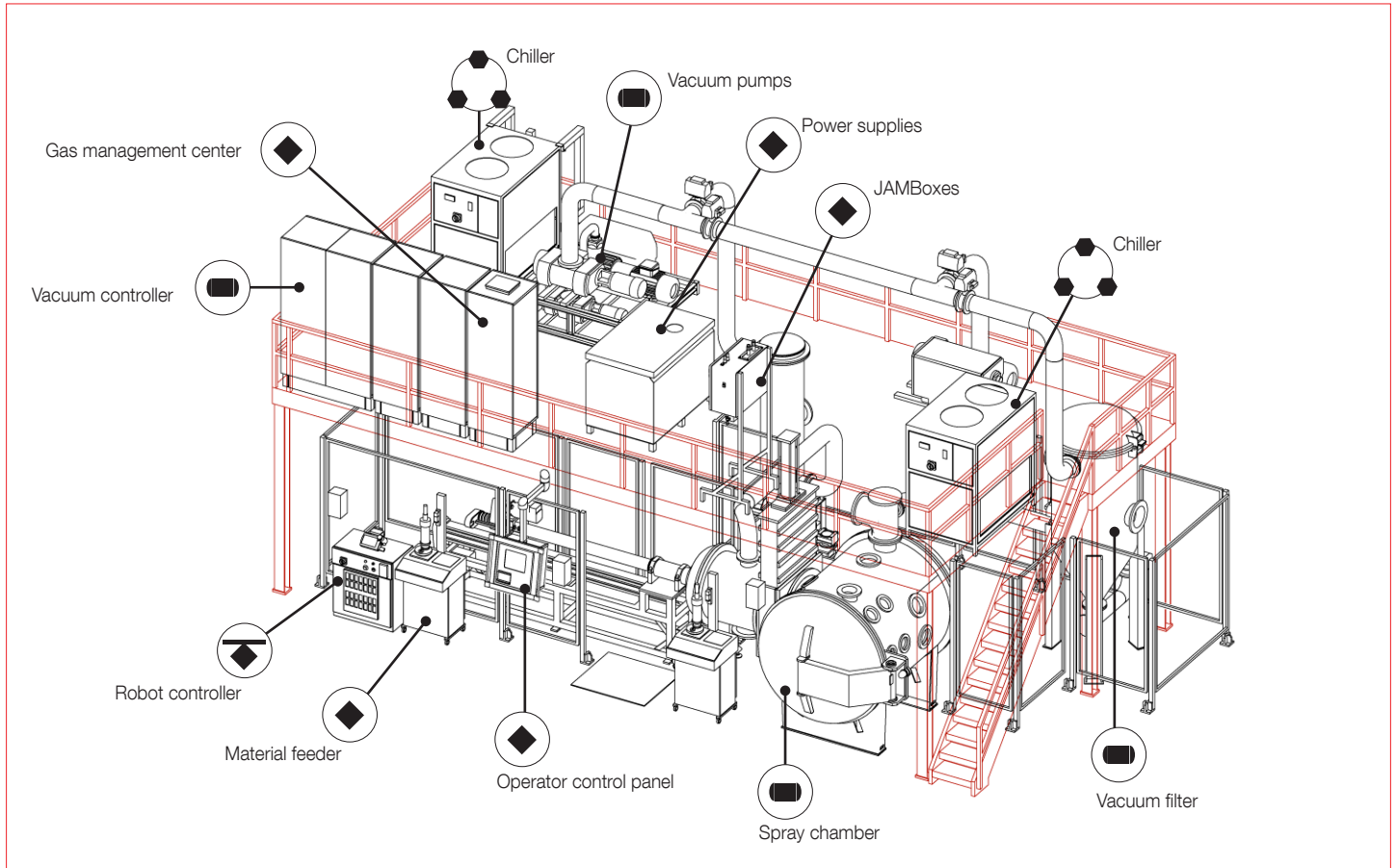

The SVPS System is equipped with a preheating chamber and a loading mechanism containing the part manipulator. This allows the chamber to be maintained under a constant, controlled atmosphere for continuous processing.

-  Core Components
-  Handling Components
-  Peripheral Components
-  ChamPro Components

Thermal spray equipment





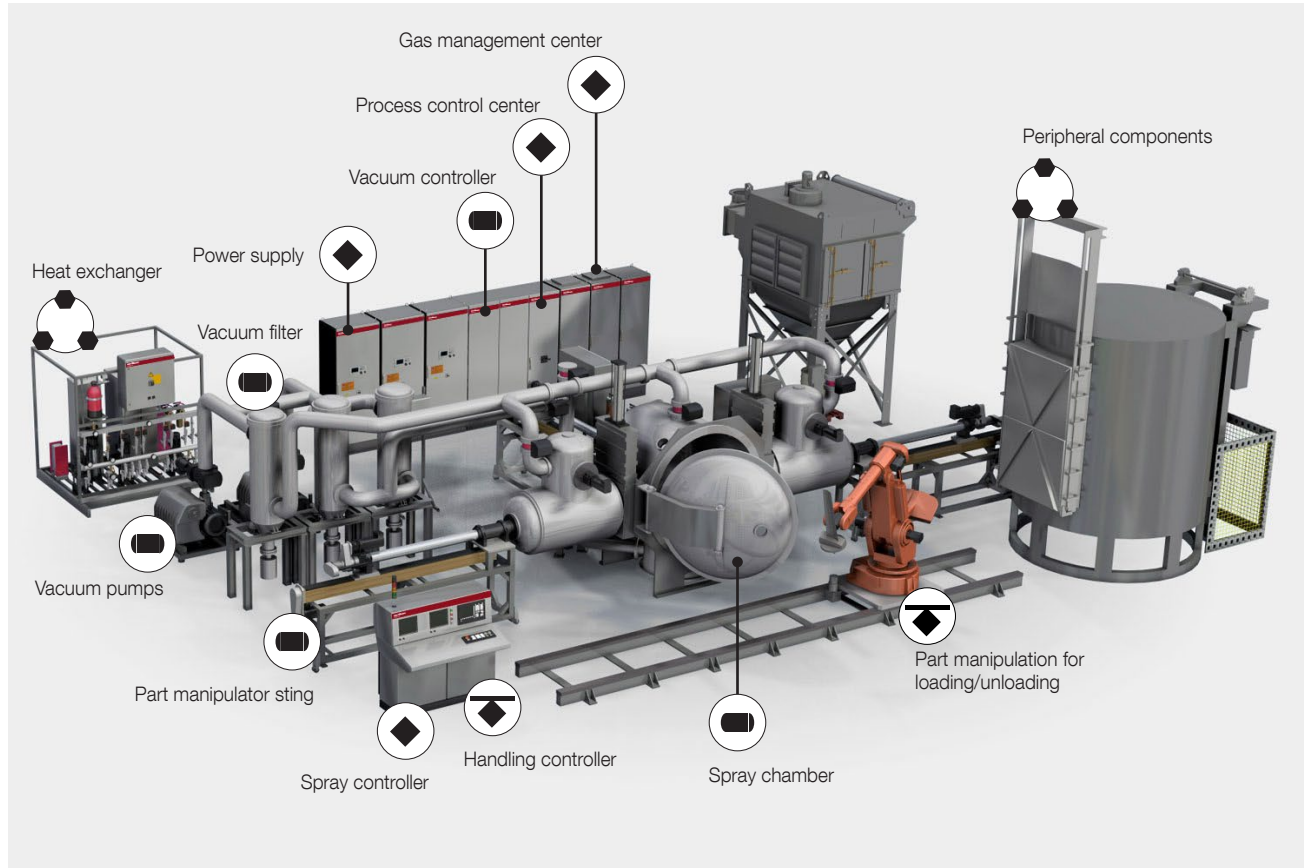

Examples of thermal spray coating systems – ChamPro™

ChamPro™ – HC-LVPS System



The HC-LVPS System is equipped with one or two loading mechanisms and preheating chambers. This allows for the continuous coating of parts; the spray chamber is maintained under a constant, controlled spray atmosphere. A robot loads and unloads the parts.

-  Core components
-  Handling components
-  Peripheral components
-  ChamPro components

Thermal spray equipment





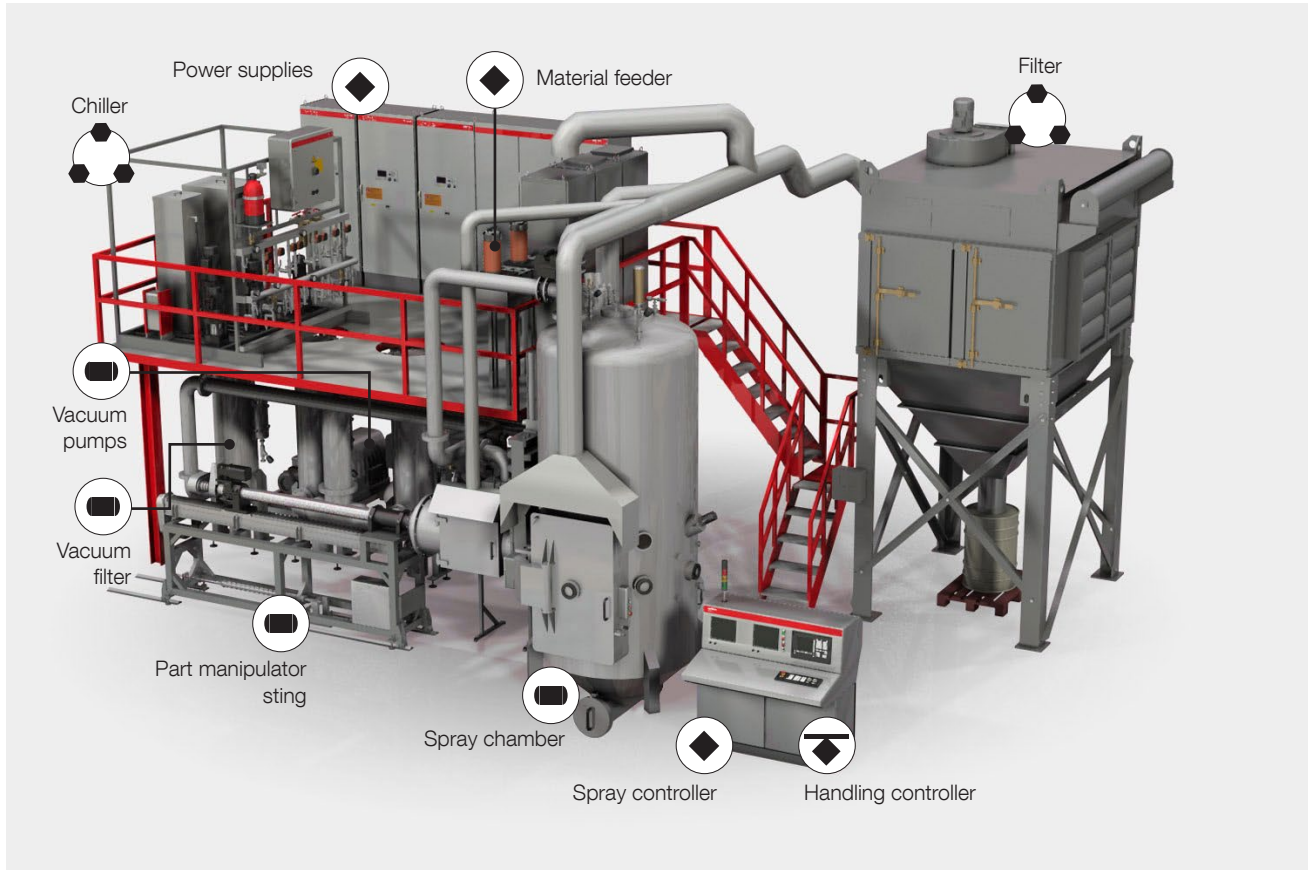

Examples of thermal spray coating systems – ChamPro™

ChamPro™ – LPPS-Hybrid System



LPPS-Hybrid represents a family of processes applied in near vacuum conditions (approx. 1 mbar or less) to produce unique, high performance functional surfaces that are quickly applied. Depending on the feedstock material, the state of deposit (liquid or vapor) and the operating parameters, the produced coatings may be thin and dense, or thick with unique microstructures.

-  Core components
-  Handling components
-  Peripheral components
-  ChamPro components

Notes

Thermal spray equipment

Advanced Technology Solutions and Services



Perfect solutions through optimum materials and innovative technologies

Oerlikon Metco is a global leader in surface engineering solutions and services offering:

- A broad range of thermal spray, and other advanced surface technology equipment
- Integrated systems and materials
- Specialized coating and surface enhancement services
- Customer support services

Oerlikon Metco provides a comprehensive manufacturing, distribution and service network,

catering to aviation, power generation, automotive and other strategic growth industries.

To take control of your surface engineering challenges, contact your Oerlikon Metco sales office, visit our web site at www.oerlikon.com/metco or e-mail us at info.metco@oerlikon.com.

*Accuraspray is a registered trademark of Tecnar Automation Ltd.

About Oerlikon Surface Solutions Division

Oerlikon is a leading global provider of surface and additive manufacturing solutions and services. The division offers an extensive portfolio of market-leading thin-film, thermal spray and additive manufacturing technologies, equipment, components and materials. Emission reduction in transportation, maximized longevity and performance of tools and components, increased efficiency and intelligent materials are hallmarks of its leadership. Pioneering technology for decades, the division serves customers with standardized and customized solutions across a worldwide network of more than 170 sites in 37 countries. With its technology brands – Oerlikon Balzers, Oerlikon Metco and Oerlikon AM – Oerlikon's Surface Solutions division focuses on technologies and services that improve and maximize performance, function, design, reliability and sustainability, which are innovative, game-changing advantages for customers in the automotive, aviation, tooling, general industries, luxury, medical, semiconductors, power generation and oil & gas markets. The division is part of the publicly listed Oerlikon Group, headquartered in Switzerland, which has 12 000 employees and generated CHF 2.65 billion in revenue in 2021. Information is subject to change without prior notice.