

High Velocity Oxy-Fuel (HVOF) Solutions

Issue 8

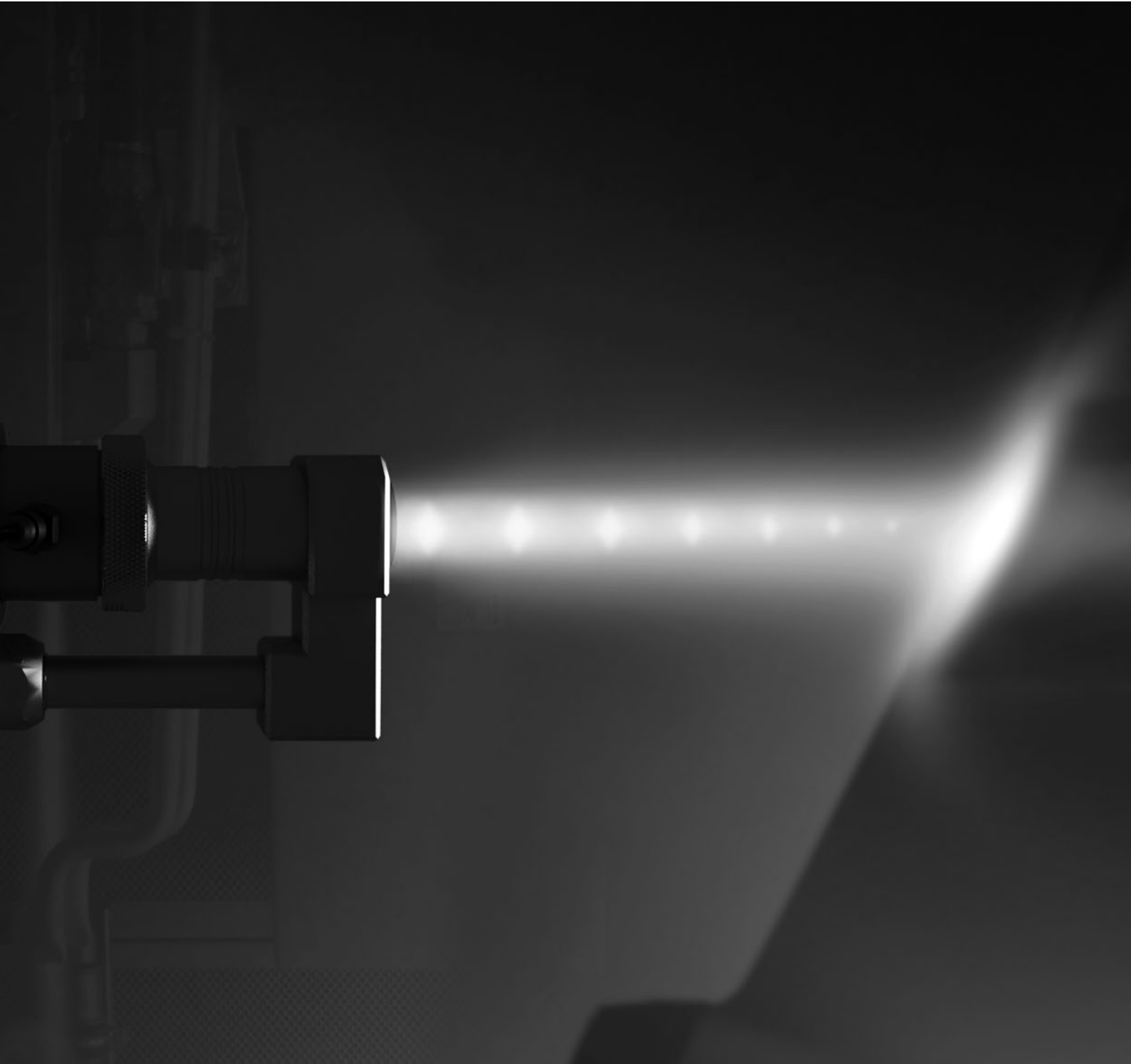

Introduction

A Continuing Tradition of Excellence

Oerlikon Metco's unsurpassed flexibility delivers optimized HVOF surfacing solutions with proven benefits and value

In 1988, Oerlikon Metco introduced its first HVOF coating solutions with a new line of spray equipment and materials. Designed to meet the need of our customers for tougher, more wear and corrosion resistant surfaces, our Diamond Jet™ equipment and Diamalloy™ materials quickly achieved market success as the innovative answer sought by many industries.

We never stopped innovating. Today, Oerlikon Metco offers our customers unparalleled freedom of choice with gas and liquid fuel HVOF solutions that perform beyond their expectations.

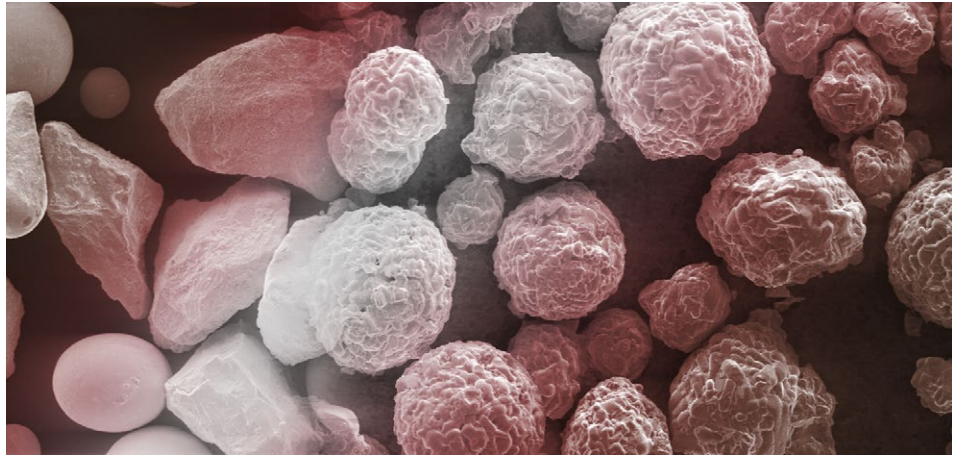

Optimum materials...

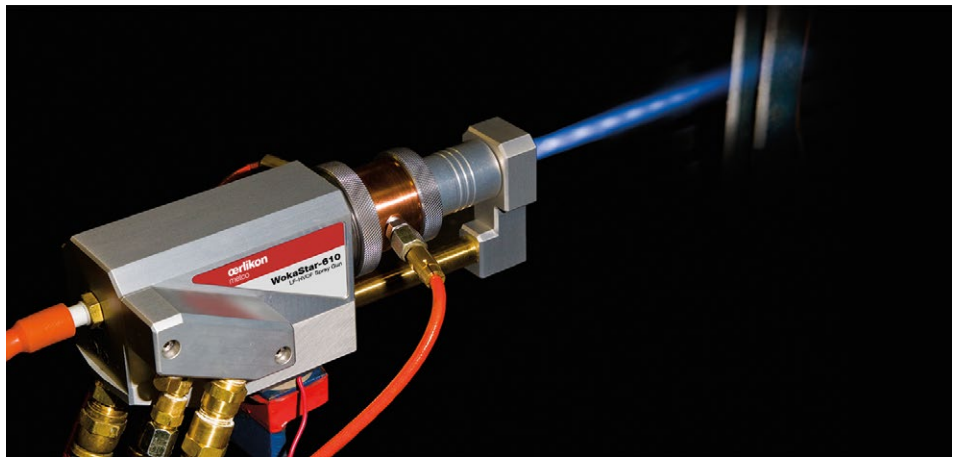

Innovative technology...

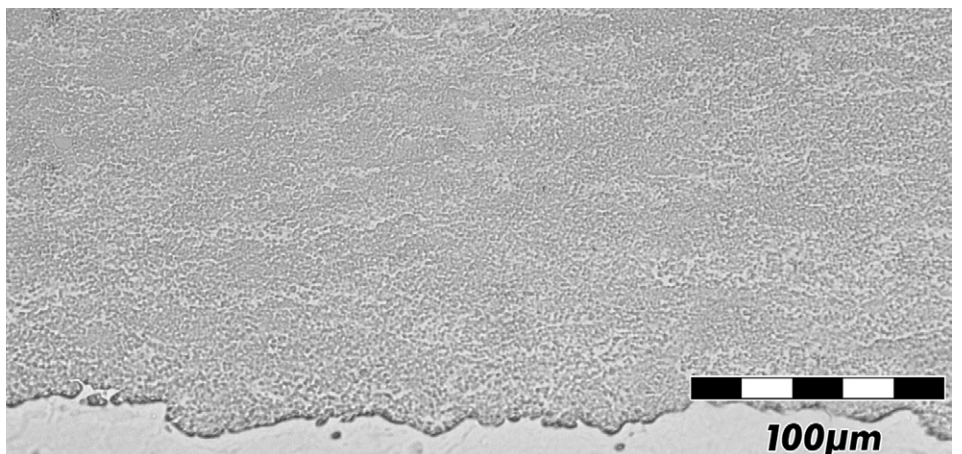

Perfect coatings...

It's the performance and value package you've been looking for!

Applications

We Meet the Challenges of the Most Demanding Applications



With Oerlikon Metco's HVOF solutions, increased performance and improved economics are not mutually exclusive concepts. Our surface engineering experts can help you to:

- Manufacture components that exhibit specific surface characteristics.
- Use less costly substrate materials for components, yet maintain high performance surface properties.
- Improve component service life.
- Repair existing components to like-new or better than new condition.
- Salvage mismachined components.
- Provide a high-performance bond coat in a coating system.

The possibilities are limitless.

Common HVOF surface applications:

Industry	Typical application
Aviation	Turbine engine fan blade mid-spans, compressor blades, turbine blade roots, bearing journals, stator and rotor disk snap diameters, landing gears, actuators, flap tracks, helicopter rotor joints and sleeves
Power Generation	Industrial gas turbines, hydroelectric Pelton buckets, nozzles and blades, exhaust fans
Automotive	Transmission shifter forks
Transportation/ Heavy Equipment	Hydraulic rods, pistons, ship steering rams
Printing and Paper/ Pulp Equipment	Print roll covers, inking rolls, calendar and press roll covers
Petrochemical	Pump components, gate valves, ball valves, valve seats, exhaust stacks, sucker rods, hydraulic rods, conveyor screws
Glass Manufacture	Glass-mould plungers
Metal Processing	Steel mill guides and rolls, wire-drawing capstans, forming dies, sheet metal cutters
Textile Machinery	Thread guides, crimping rolls
General Industry	Pump housings, impellers and shafts, plastic extruders, cam followers, wear rings, machine bedways, press fits, restoration of machinery components

Characteristics

Advanced HVOF Technology for Superior Coating Characteristics

Coatings produced using HVOF have outstanding characteristics, even above other thermal spray processes, that include:

- **High density:** Typical coatings have less than 2% porosity and some coatings as low as 0.5% porosity.
- **High bond strength:** For example, typical carbide coatings sprayed with HVOF exhibit bond strengths in excess of 69 MPa (10,000 psi). Other coating materials sprayed with HVOF have significantly higher bond strengths than the same materials applied using other atmospheric thermal spray processes such as air plasma spray.
- **Optimum Hardness:** A 12% tungsten carbide/cobalt coating will have a typical micro hardness of 1100 to 1350 DPH300.
- **Improved Toughness:** Depending on chemistry and other factors, the

short dwell time and lower temperatures of HVOF can produce wear resistant coatings with excellent impact resistance.

- **Higher Coating Thickness:** Coatings exhibit greater coating thickness limits than plasma, combustion or wire coatings of the same coating material. These high thickness limits are attributed to a stress-relieving 'shot-peening' effect produced by the high velocity particles impacting upon the previous layers of coating. Some tungsten carbide coatings can have a thickness greater than 6.4 mm (0.250 inches).
- **Beneficial Residual Stress:** Compressive residual stresses and, in some cases, very low tensile stresses enhance the fatigue life of a coated component, reduce the susceptibility of cracking and permit greater coating thickness limits.

- **Excellent Wear Resistance:** HVOF coatings can exhibit superior resistance to sliding/adhesive wear, fretting, erosion or cavitation depending on the material and process parameters chosen.
- **Superb Corrosion Resistance:** The high density and exceptional metallurgical properties of HVOF coatings provide enhanced resistance to the effects of corrosion, including hot corrosion, oxidation and the effects of corrosive media such as acidic and alkaline atmospheres and liquids.
- **Fine Surface Finishes:** Smooth surface finishes allow HVOF-produced coatings to be used in the as-sprayed condition for many applications. Coatings can be machined, ground, lapped, honed or super-finished to produce very high surface finishes to precise tolerances.

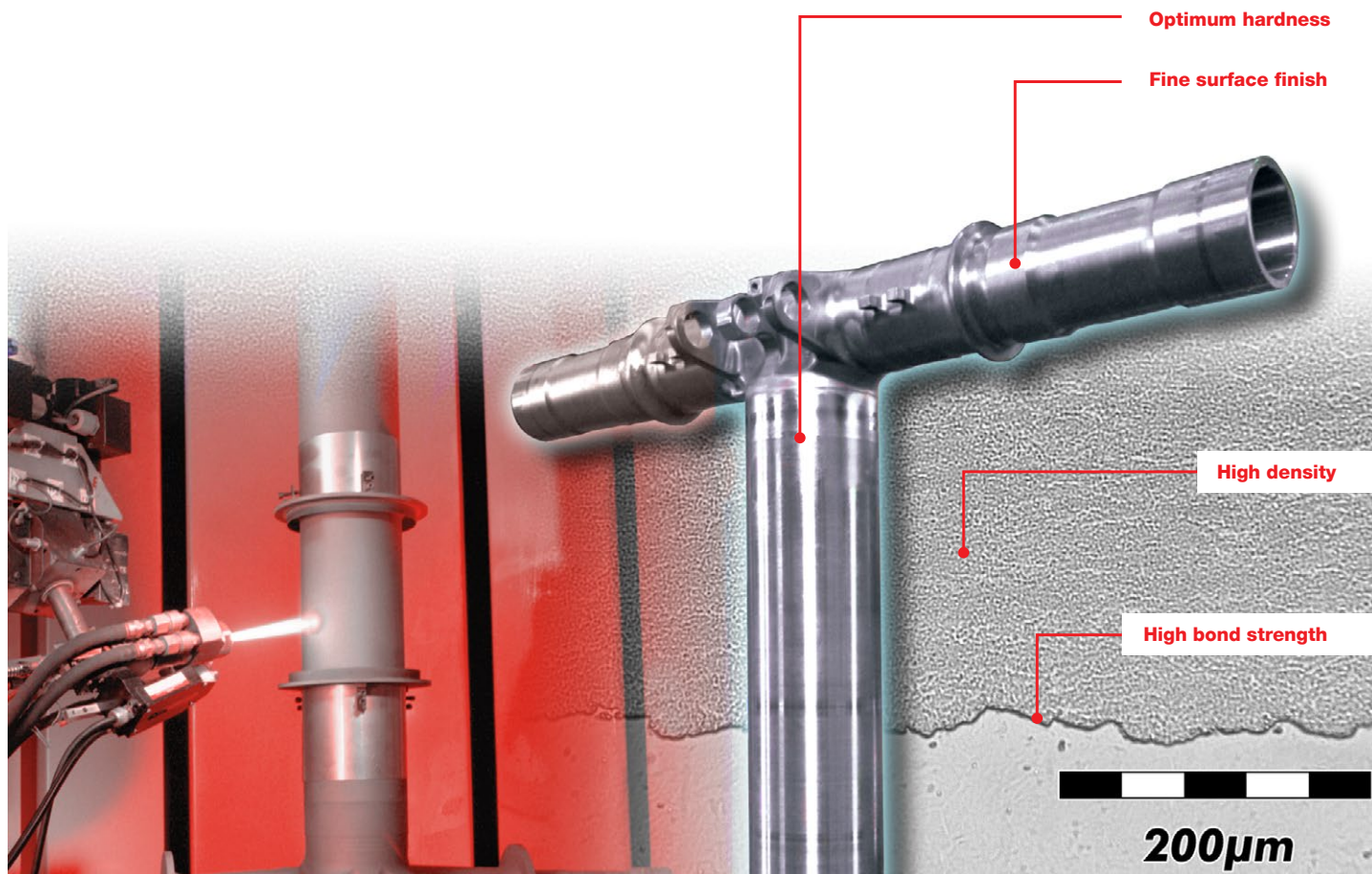

Process

Proven to Produce Reproducible Surfaces to Exacting Requirements

The HVOF process efficiently combusts oxygen and a gaseous or liquid fuel to produce high kinetic energy with controlled heat input. The coating material, in powder form, is introduced into and uniformly heated by the hot gas stream to a molten or semi-molten condition. The flame and powder are accelerated by a converging/diverging nozzle (air

cap) to produce supersonic gas and particle velocities, which propel the powder particles toward the substrate to be coated.

The powder particles flatten plastically upon impact with the substrate; cooling and solidifying to form the coating.

High particle velocities, uniform heating and low dwell time combine to produce coatings that are very dense and tightly bonded to the substrate. Coating chemistries are more predictable and coatings have fine, homogeneous microstructures.

Gas-fuel HVOF gun

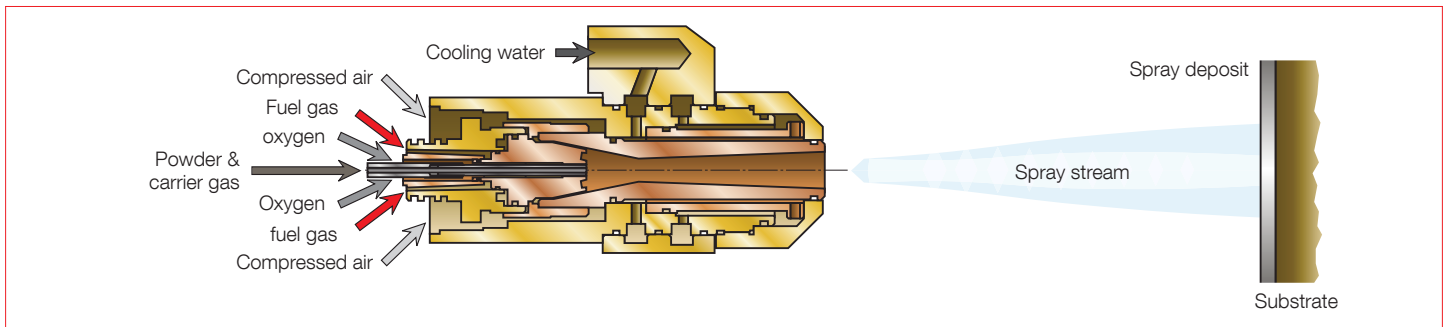

Liquid-fuel HVOF gun

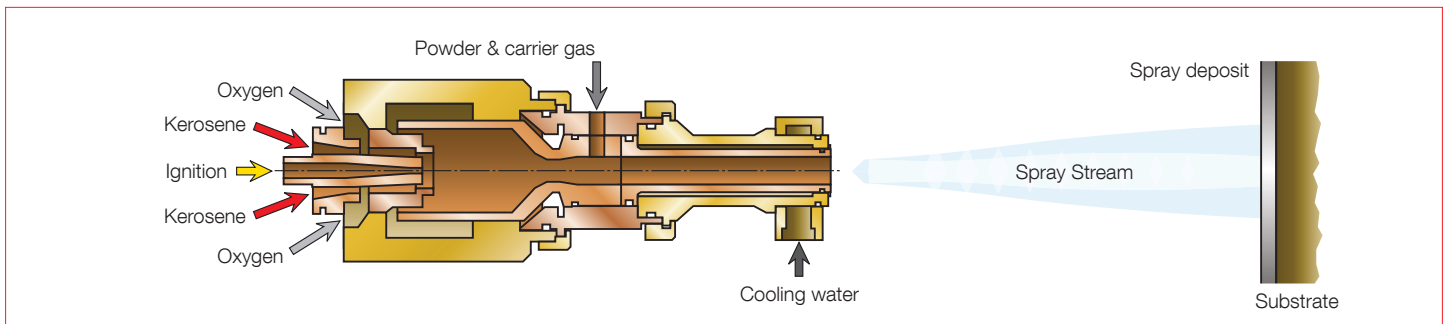

The HVOF (High Velocity Oxy Fuel) spray process

Flexibility

Flexible Process Choices Result in Surfaces Engineered for Specific Applications

At Oerlikon Metco, we know our customers have unique needs and application goals, so we offer the widest range of process choices to ensure we meet your exact expectations.

- **Choice of Coating Materials:** Choose from a wide variety of coating materials including pure metals,

metallic alloys, metallic blends, carbides and self-fluxing materials, tailored to gas or liquid fuel systems.

- **Fuels:** Gas-fueled systems can use hydrogen, ethylene, propane, propylene or natural gas. Liquid-fueled systems can use Jet-A or kerosene. Choose the fuel process that is suitable to your production

requirements, economics and coating quality needed.

- **System Options:** Choose the system configuration that fits your budget and production requirements, with a choice of standard and customized part manipulators and gun manipulators.

Gas Fuel or Liquid Fuel Oerlikon Metco Delivers!



Which is right for your application? Your choice of a gas fuel or liquid fuel system will depend on many factors that can include:

- Configuration/geometry of the part to be coated
- Substrate composition
- Coating material to be applied
- Desired coating thickness
- Applicable customer coating specifications
- Desired as-sprayed surface roughness
- Desired finished surface roughness
- Desired coating internal stresses
- Number of parts to be coated
- Size of coated area
- Utilities to be used (process media, air, water, etc.)

Let us help you decide on the technology that's right for you. Only Oerlikon Metco has the experience you need for both gas fuel and liquid fuel HVOF technologies. Using our broad portfolio of HVOF coating materials, our Coating Solution Center specialists can develop your surface solution using the best HVOF process technology for your application. Our System integration experts will design an HVOF system that is exactly suited to your production and budget requirements. It's the Oerlikon Metco difference!

General comparison of gas fuel and liquid fuel HVOF technologies:

Comparison	Gas fuel HVOF	Liquid fuel HVOF
Gun	Water-cooled Diamond Jet Gun	WokaJet-410 Gun
General characteristics		
Fuel options	H ₂ , CH ₄ , C ₂ H ₄ , C ₃ H ₆ , C ₃ H ₈	Jet-A or Kerosene
Combustion pressure	~ 0.55 MPa (80 PSI)	0.55 to 0.83 MPa (80 to 120 PSI)
Gas velocity	1800 to 2100 m/s (5900 to 6900 ft/s)	2000 to 2200 m/s (6500 to 7200 ft/s)
Particle velocity	450 to 600 m/s (1475 to 1975 ft/s)	475 to 700 m/s (1550 to 2300 ft/s)
Powder injection	Axial feed (hotter zone)	Radial feed (cooler zone)
Powder injection pressure	Higher	Lower
Spray rate	up to 120 g/min (16 lb/h)	up to 200 g/min (26.5 lb/h)
Consumption comparison (typical utility consumption per hour of operation)		
Fuel	43800 l (1670 ft ³) H ₂ , or 5280 l (200 ft ³) C ₃ H ₆ , or 5280 l (200 ft ³) C ₃ H ₈	28 l (7.3 gal) kerosene
Oxygen	18420 l (700 ft ³)	61400 l (2335 ft ³)
Water	600 l (160 gal)	2375 l (625 gal)

Key Elements of an HVOF Solution

Building Blocks of a Successful HVOF Solution

Key components: Key elements are required for all HVOF spray systems. These include the coating material to be applied, a powder feeder to deliver the coating material to the spray gun, the HVOF spray gun that will heat the coating material and propel it to the workpiece, and a control system that accurately controls the gas flows required for HVOF combustion.

Handling equipment: In all but the most simple of manual spray systems, handling equipment precisely controls the movement of the spray gun and workpiece, and the position of the gun relative to the workpiece.

Peripheral equipment: Most HVOF spray installations require a cooling water system for the spray gun and it is often necessary to have cooling air to control the temperature of the workpiece. In addition, a soundproof cabin and an air filtration and exhaust system protect both personnel and the environment.

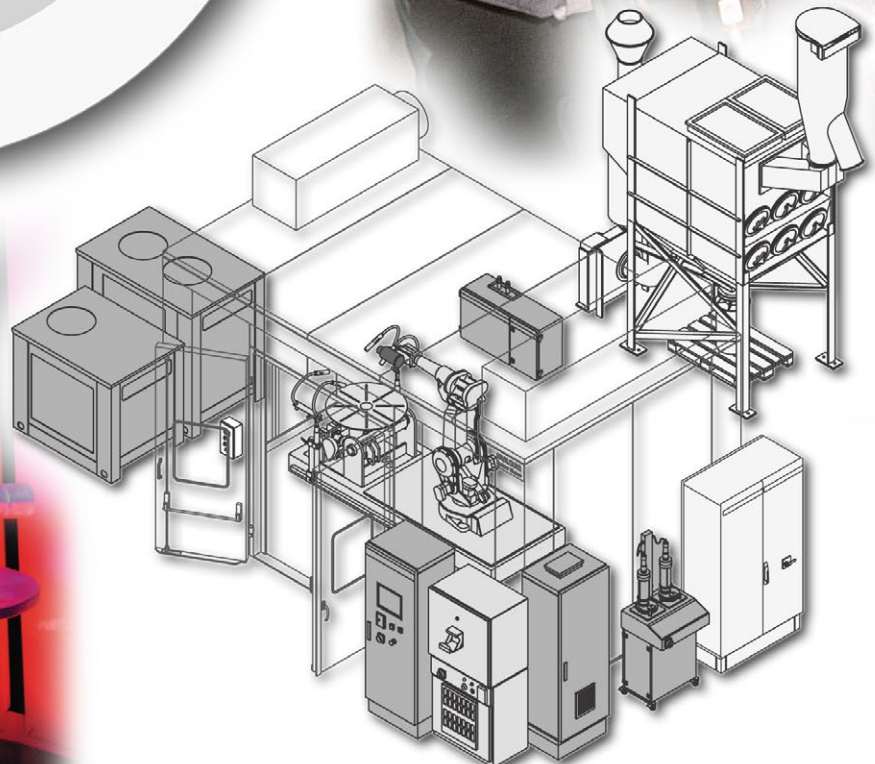
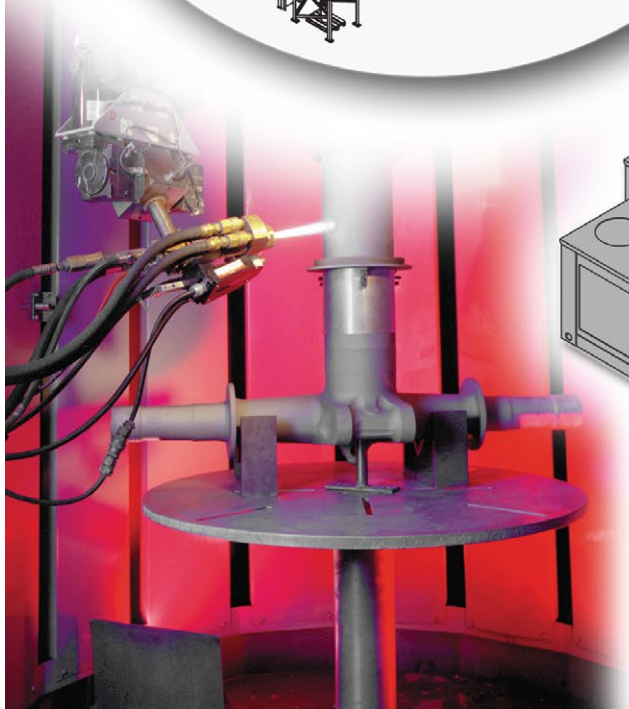
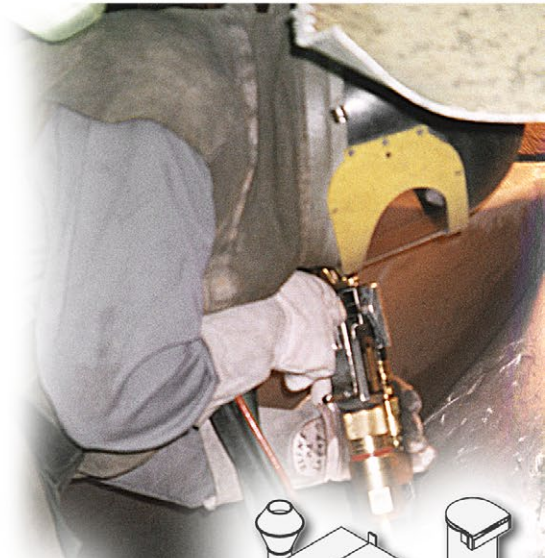
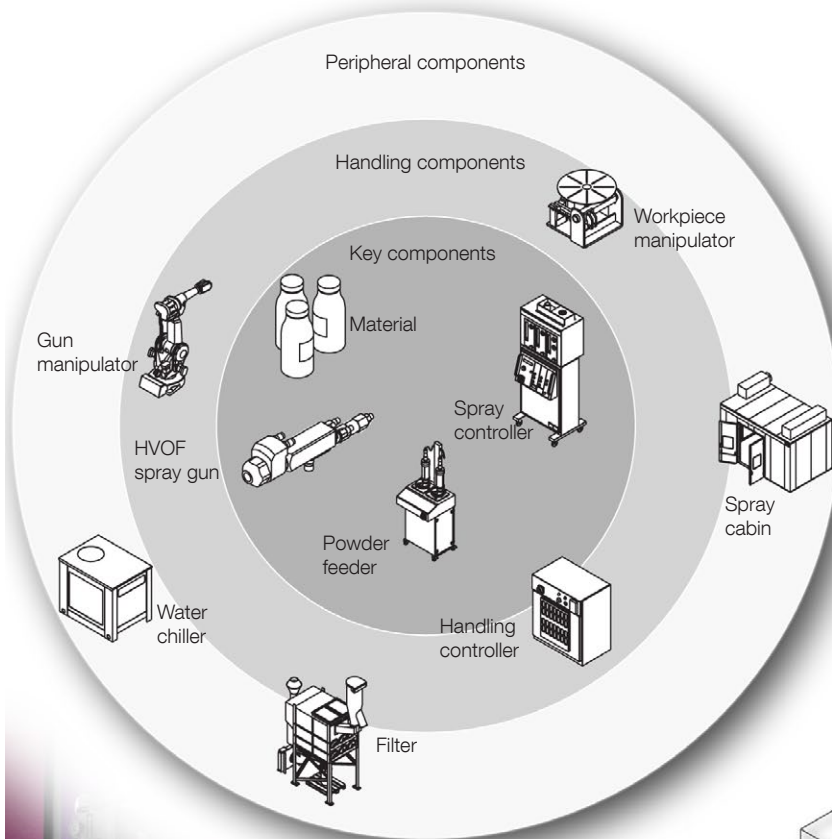

Fully automated HVOF spray system

Materials

Every Successful Application Starts with the Right Material Choice

Oerlikon Metco's portfolio of HVOF coating materials is designed to achieve optimum results, with each product sized and formulated for the selected HVOF process. Our specialists will consult with you to determine the

ideal candidate for your application from our diverse line of material chemistries.

Do you already own a system with an HVOF gun not produced by Oerlikon

Metco? You can still benefit from an Oerlikon Metco HVOF material solution! Many of our HVOF products are available in a variety of particle sizes optimized for popular HVOF spray guns.

Product	Composition	Wear resistance	Corrosion resistance	Oxidation/ sulfidation resistance	High temperature service	Restoration/ build up
WOKA 31xx	Tungsten Carbide – 12 % Cobalt	●				
Metco 5812	Tungsten Carbide – 12 % Cobalt	●				
Metco 5810	Tungsten Carbide – 12 % Cobalt	●				
Diamalloy 2004	Tungsten Carbide – 12 % Cobalt	●				
Diamalloy 2003	Tungsten Carbide – 12 % Cobalt	●				
WOKA 32xx	Tungsten Carbide – 12 % Cobalt	●				
Metco 514x	Tungsten Carbide – 17 % Cobalt	●				
Diamalloy 2005NS	Tungsten Carbide – 17 % Cobalt	●				
Metco 516x	Tungsten Carbide – Cobalt – Chrome Alloy	●	●			
WOKA 365x	Tungsten Carbide – Cobalt – Chrome Alloy	●	●			
Diamalloy 5849	Tungsten Carbide – Cobalt – Chrome Alloy	●	●			
Amdry 5843	Tungsten Carbide – Cobalt – Chrome Alloy	●	●			
Metco 5847	Tungsten Carbide – Cobalt – Chrome Alloy	●	●			
WOKA 36xx	Tungsten Carbide – Cobalt – Chrome – Nickel Alloy	●	●			
WOKA 37xx	Tungsten Carbide – 20 % Chrome Carbide – 7 % Nickel	●	●			
WOKA 33xx	Tungsten Carbide – 10 % Nickel	●	●			
Metco 5803	Tungsten Carbide – 12 % Cobalt / Nickel Superalloy Blend	●	●			
Metco 82VF-NS	Chrome Carbide – 7 % Nickel Chrome	●			●	
Diamalloy 3007	Chrome Carbide – 20 % Nickel Chrome	●			●	
WOKA 71xx	Chrome Carbide – 20 % Nickel Chrome	●			●	
Amdry 5260	Chrome Carbide – 25 % Nickel Chrome	●			●	
WOKA 72xx	Chrome Carbide – 25 % Nickel Chrome	●			●	
WOKA 73xx	Chrome Carbide – 25 % Nickel Chrome (Hipped)	●			●	
Diamalloy 3004	Chrome Carbide – 25 % Nickel Chrome (Blend)	●			●	
Metco 5241	Chrome Carbide – Nickel Alloy	●		●	●	
WOKA 75xx	Chrome Carbide – 37 % Tungsten Carbide – 18 % Metallic Alloy	●		●	●	
WOKA 74xx	Chrome – Iron Carbide – 20 % Nickel	●	●	●	●	
Diamalloy 4060NS	Cobalt – Chrome Alloy	●	●	●	●	
Diamalloy 3001	Cobalt – Molybdenum Alloy	●	●	●	●	
Diamalloy 3002NS	Cobalt – Molybdenum Alloy	●	●	●	●	
Diamalloy 1007	Copper		●			●
Diamalloy 1004	Copper Alloy (Aluminum Bronze)	●	●			
Diamalloy 1003	AISI Type 316 Stainless Steel	●				●
Diamalloy 1003-1	AISI Type 316 Stainless Steel	●				●
Diamalloy 1008	Iron/Chrome Blend	●	●			

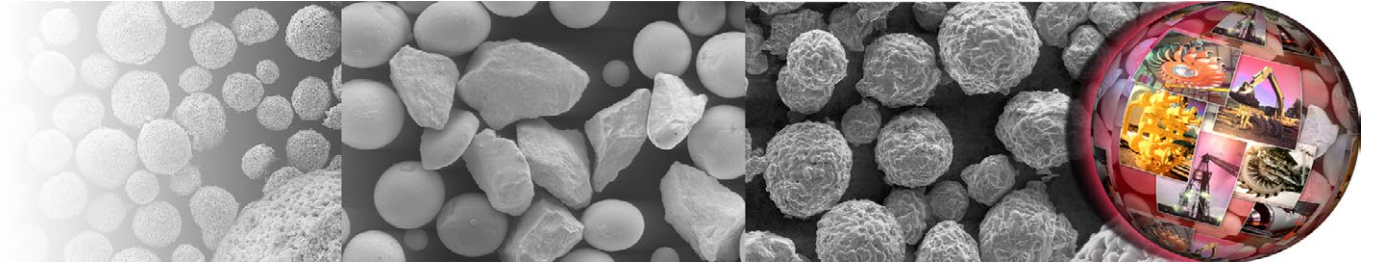

Product	Composition	Wear resistance	Corrosion resistance	Oxidation/sulfidation resistance	High temperature service	Restoration/build up
Diamalloy 4008NS	Nickel – Aluminum Alloy		●			●
Amdry 4532	Nickel – Chrome Alloy		●			
Amdry 4535	Nickel – Chrome Alloy		●			
Diamalloy 1005	Inconel 718*		●			●
Diamalloy 4004NS	Rene 80*		●			●
Diamalloy 1006	Inconel 718*		●			●
Diamalloy 4006	Nickel – Chrome Alloy with Amorphous Phases	●	●			
Amdry 1718	Inconel 718*		●			●
Metco 4538	Nickel – Iron – Chrome Alloy				●	
Diamalloy 2001	Nickel – Chrome Alloy (Self-Fluxing)	●	●			
Diamalloy 2002	Tungsten Carbide Cobalt /Nickel Alloy Blend (Self-Fluxing)	●	●			
Diamalloy 4454	CoNiCrAlY		●	●	●	
Amdry 9951	CoNiCrAlY		●	●	●	
Amdry 9954	CoNiCrAlY		●	●	●	
Diamalloy 4700	CoNiCrAlY		●	●	●	
Amdry 997**	NiCoCrAlY		●	●	●	
Amdry 365-1	MCrAlY (Proprietary)		●	●	●	
Amdry 386**	MCrAlY (Proprietary)		●	●	●	

Product designations marked with an x indicate the availability of a variety of particle size ranges optimally sized for different HVOF spray guns.

* Inconel is a registered trademark of International Nickel; Rene is a registered trademark of GE.

** Product sized for HVOF supplied upon request.

Spray Systems

Ensure the Success of Your Application with the Right System

Typical manual HVOF spray system



1. DJF gas controller
2. Hand-held DJ gun with water-cooled air cap
3. DJFEW water sensing interface unit (for use with water cooled DJ gun)
4. Powder feeder 5MPE-HP
5. Water chiller Climet RC-HV (for use with water cooled DJ gun)
6. 6A air filtration and control unit

Only Oerlikon Metco has an equipment portfolio designed to meet your unique needs. Shown here are just a few examples of system configurations. Let our team of experts support you in designing your perfect system.

Diamond Jet Manual, Gas fuel HVOF Spray System

- Ideal for small shops with occasional surfacing needs
- Precision components for reliable coating results, designed with safety in mind

- Rotameter gas metering system
- Choose an air-cooled Diamond Jet spray gun or a high-performance, water-cooled Diamond Jet spray gun in manual (hand-held) or automatic (machine-mount) models
- Customize your system with gun and part manipulation equipment ideal for your spray applications

Spray Systems

Ensure the Success of Your Application with the Right System

Typical semi-automatic HVOF spray system



Oerlikon Metco DJC semi-automatic, gas fuel HVOF spray system

- Ideal for small to medium shops with moderate surfacing needs
- Semi-automatic operation for accurate and repeatable HVOF coatings
- Programmable Logic Control (PLC) based controller with rotameter gas metering system
- Built-in monitoring and alarm system with automatic shutdown for safe operation
- Interfaces with workpiece handling equipment, gun manipulators, exhaust system and accessories
- Choose an air-cooled Diamond Jet spray gun or a high-performance water-cooled Diamond Jet spray gun in manual (hand-held) or automatic (machine-mount) models
- Customize your system with gun and part manipulation equipment ideal for your spray applications

Spray Systems

Ensure the Success of Your Application with the Right System

Typical UniCoatPro LF automated HVOF spray system



Oerlikon Metco UniCoatPro automatic liquid fuel spray system

- Ideal for medium to large shops with high-volume surfacing needs and increased quality control requirements
- Fully-automatic operation for highly accurate and repeatable HVOF coatings
- Programmable Logic Control (PLC) based controller with mass-flow control gas metering system
- User friendly, color touch-screen programming with storage for 100 spray recipes
- Advanced diagnostics, monitoring and control with multi-level alarm system and automatic shutdown for safe operation
- Digital data bus interface to work-piece handling equipment, gun manipulators, exhaust system and accessories

Spray Systems

Ensure the Success of Your Application with the Right System

Typical MultiCoat advanced automated HVOF spray system



Oerlikon Metco MultiCoat advanced HVOF gas fuel/liquid fuel spray system

- The most advanced system platform on the market!
- Ideal for medium to large shops with many different surfacing needs, R&D facilities, and moderate to high-volume production needs
- Configurable for multiple spray processes including gas fuel HVOF, liquid fuel HVOF, plasma, combustion powder and wire spray – all of which can be controlled from a single controller
- Fully-automatic operation for highly accurate and repeatable coatings
- Twin-Brain design with PC-based operator console and Programmable Logic Control (PLC) based controller with mass-flow control gas metering system
- User friendly, color touch-screen programming with storage for 1000 spray recipes
- Advanced diagnostics, monitoring and control with multi-level alarm system and automatic shutdown for safe operation
- Digital data bus interface to work-piece handling equipment, gun manipulators, exhaust system and accessories

Flexible Choices

HVOF Spray Guns, Powder Feeders, Handling Equipment

Oerlikon Metco HVOF spray guns

Gas fuel

Air-cooled Diamond Jet Gun

- Produces quality coatings
- Manual (hand-held) and automatic (machine-mount) models
- Uses hydrogen, propane or propylene fuel



Water-cooled Diamond Jet Gun

- Produces superior coatings for critical applications
- Manual and automatic models
- Uses hydrogen, propane, propylene, ethylene* or methane* (natural gas) fuel



Liquid fuel

WokaJet-410**, WokaJet-410-S, WokaJet-410-Sz

- Produces quality coatings
- Minimal carbon build-up
- Automatic (machine-mount)
- Uses kerosene fuel



WokaStar-610**, WokaStar-610-S, WokaStar-610-Sz

- High-quality coatings, improved thermal efficiency
- Extended spare part life
- Automatic
- Uses kerosene fuel



Oerlikon Metco HVOF powder feeders

5MPE-HP

- Gravimetric / fluidic powder feed operation
- PFRM feed rate monitor included
- Large, 3.2 liter hopper
- For use with HVOF, air plasma and combustion powder Therospray systems



9MP-DJ

- Gravimetric / fluidic powder feed operation
- Closed-loop feed rate monitoring and control
- Rotameter and mass flow carrier gas metering models available
- Large, 3.2 liter hopper
- For use with HVOF, air plasma and combustion powder Therospray systems



Single-220-H

- Highly accurate volumetric feed operation
- Closed-loop feed rate monitoring and control
- Single 1.5 liter hopper
- For use with MultiCoat spray platforms



Twin-120-H, Twin-140

- Highly accurate volumetric feed operation
- Dual 1.5 liter hoppers
- Twin-120-H for use with MultiCoat; Twin-140 for use with UniCoatPro LF spray platforms



Oerlikon Metco HVOF handling equipment

Customize your spray system with gun and part manipulation equipment from Oerlikon Metco that includes robotic manipulators, turntables, vertical and horizontal traverses and more.

Specialized handling requirements? No problem! We can custom design, fabricate and test exactly what you need.



* used with automatic models; can be used with hand-held water cooled DJ gun if ordered with an optional hydrogen ignition kit, available on a special order basis.

** WokaJet-410 and WokaStar-610 with hydrogen ignition

Services

Oerlikon Metco Essential Services for On-Going Success



Training

Let our staff professionally train your personnel on the safe operation and maintenance of your thermal spray systems.



Field service

Qualified, factory-trained field service technicians will keep your systems in peak operating condition. Our field services include flexible maintenance contracts, emergency break-down repairs and troubleshooting help.



Traceability

Fully traceable calibrations, including gas flows and pressures, ensure the accuracy and repeatability of your spray facilities.

Application consultation services

Our thermal spray professionals can consult with you for a total application solution with optimized benefits and value.

Consumable and spare parts support

Oerlikon Metco brand consumable and spare parts keep your coating facilities operating with repeatable results.

Simplified sourcing

Simplify your purchasing decisions with Oerlikon Metco quality consumable parts and materials for competitive HVOF spray guns.

Global sales and logistics

Oerlikon Metco professionals are prepared to help, wherever your location.

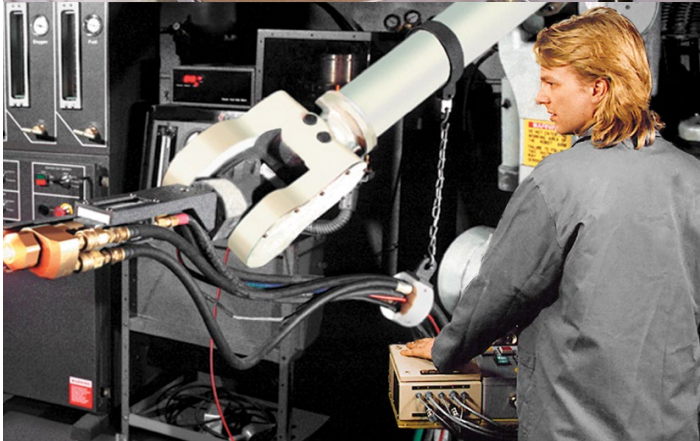

Make or buy – it's your decision

If you would prefer to outsource your coating work, Oerlikon Metco is ready to serve you. We have first-rate coating facilities on every major continent around the globe. The surface engineering experts at the Oerlikon Metco coating service facility of your choice are ready to consult with you and provide your company with expert coating and machining services.



Perfect solutions through optimum materials and innovative technologies

Oerlikon Metco is a global leader in surface engineering solutions and services offering:

- A broad range of thermal spray and other advanced surface technology equipment and materials
- Integrated systems
- Specialized coating and surface enhancement services
- Customer support services

Oerlikon Metco provides a comprehensive manufacturing, distribution and service network, catering to aviation, power generation, automotive and

other strategic growth industries.

To take control of your surface engineering challenges, contact your Oerlikon Metco sales office, visit our website at www.oerlikon.com/metco or email us at info.metco@oerlikon.com

About Oerlikon Surface Solutions Division

Oerlikon is a leading global provider of surface and additive manufacturing solutions and services. The division offers an extensive portfolio of market-leading thin-film, thermal spray and additive manufacturing technologies, equipment, components and materials. Emission reduction in transportation, maximized longevity and performance of tools and components, increased efficiency and intelligent materials are hallmarks of its leadership. Pioneering technology for decades, the division serves customers with standardized and customized solutions across a worldwide network of more than 170 sites in 37 countries. With its technology brands – Oerlikon Balzers, Oerlikon Metco and Oerlikon AM – Oerlikon's Surface Solutions division focuses on technologies and services that improve and maximize performance, function, design, reliability and sustainability, which are innovative, game-changing advantages for customers in the automotive, aviation, tooling, general industries, luxury, medical, semiconductors, power generation and oil & gas markets. The division is part of the publicly listed Oerlikon Group, headquartered in Switzerland, which has 12 000 employees and generated CHF 2.65 billion in revenue in 2021. Information is subject to change without prior notice.