

# Wire Combustion Solutions

Issue 6





# Introduction

## Improving on a 80+ Year Tradition of Excellence ...

Optimum materials...



Innovative technology...



Perfect coatings...

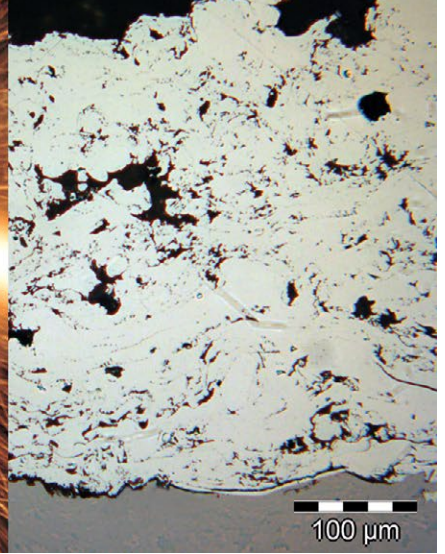

It's the performance and value package you've been looking for!

### **Oerlikon Metco's Wire Combustion Thermal Spray systems set the industry standard for heavy-duty performance**

Out in the field or in your facility, wire combustion spray is the time-tested method for applying anti-corrosion coatings and performing dimensional surface restorations. When it comes to devising innovative wire combustion thermal spray solutions that enhance productivity and profitability, Oerlikon Metco has set the industry standard. We introduced the world to wire combustion spray coating technology more than half a century ago... And we've been the global leader ever since.

The results are self-evident: Oerlikon Metco Wire Combustion Systems are more economical to use, easier and safer to operate, and deliver precision control superior to anything else on the market.



In the steel industry, combustion wire spray enhances productivity, extends component life and reduces operating costs.

# Applications

## Perfecting the Process to Suit the Application



The oil and gas industry utilize Wire Combustion Spray for corrosion protection, including long-lasting prevention of CUI (Corrosion Under Insulation).

When your engineering challenges require a metal coating to enhance the properties of a given surface, Oerlikon Metco's Wire Combustion Spray Systems are the ideal solution. Utilized extensively throughout the maritime, paper/pulp/printing, manufacturing, steel, aerospace, automotive, and railroad industries, these systems increase both the efficiency and lifetime of numerous parts and components.

The process involves:

- Drawing a metal alloy wire through the combustion spray gun via a set of drive rolls that are powered by an air turbine or an electric motor
- At the gun nozzle, fuel gas mixes with oxygen to create an intense flame, which is then shaped at the gun's air cap by compressed air
- The metal wire is atomized, and the molten droplets are propelled at high velocity onto a surface specially prepared for wire combustion spraying through degreasing, media blasting, or by simply masking off a specific area
- The spray layers solidify to form a tough thermal coating that bonds with the chosen surface, endowing it with one or more performance-enhancing characteristics

Surface property	Typical applications
Corrosion protection	Corrosion Under Insulation (CUI), bridges, ships, large steel structures, cell towers, galvanized tubing (Tube Mills)
Wear protection	Rotating heavy equipment, piston rings, synchronizing rings
Surface restoration	Hydraulic rods and plungers, worn, or mismatched/mis-machined parts
Electrical/thermal conductivity	EMI shielding
Decorative surfaces	Surface restoration, art, cosmetic treatments
Coating of internal surfaces (with optional gun extension)	Bearing journals, bell housings, transmission cases, motor blocks



# Profitability

## Increasing Productivity and Profitability Six Ways

Our Wire Combustion Spray Systems deliver the highest quality thermal spray coatings available, under a variety of diverse conditions, improving productivity while protecting your bottom-line profits.

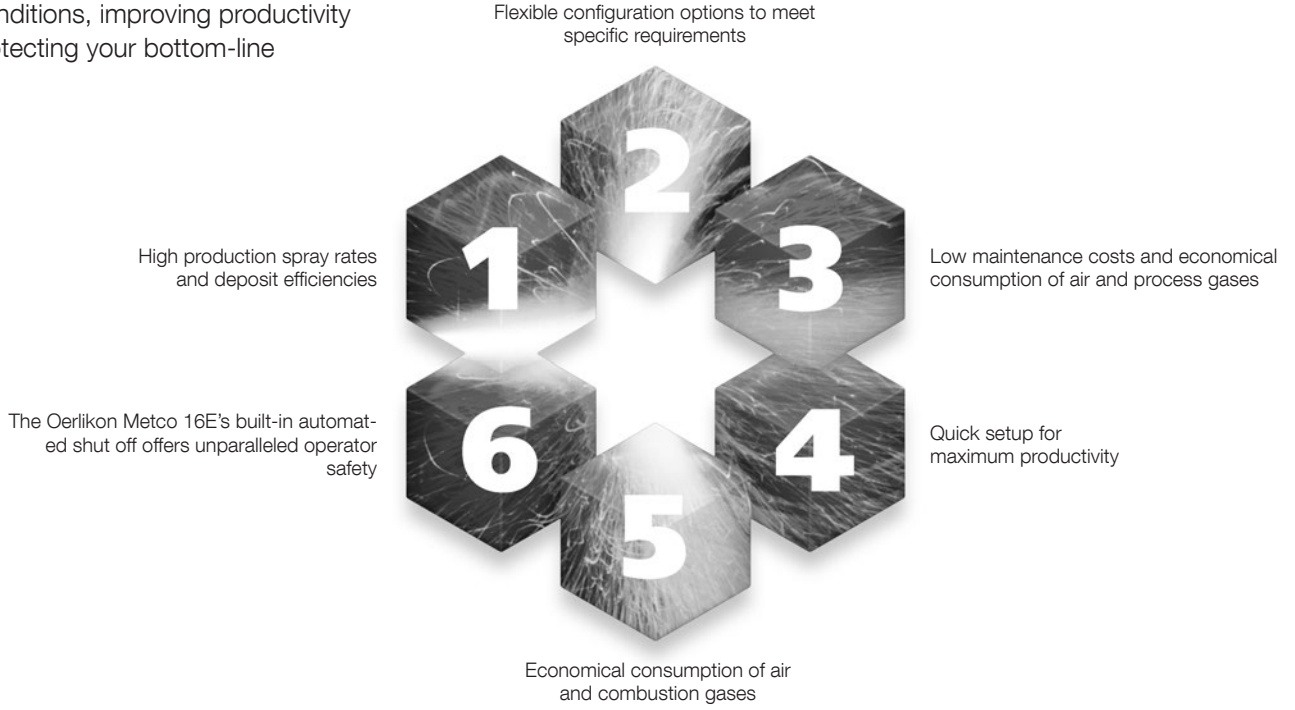

Flexibility, economy, and superior deposition rates make Oerlikon Metco's Wire Combustion Spray the thermal spray system of choice in the maritime industry.

# Key Features

## Key Features That Deliver Added Value



Wire combustion spraying on the inside of chemical and petroleum storage tanks delivers superior, yet cost-effective corrosion resistance.

- Throughout our systems, precision flow control valves monitor actual flow rates of air, oxygen and fuel to the gun nozzle
- Precision flow rate metering, accurate within  $\pm 5\%$  at any flow rate, is made possible by our unique Oxygen Fuel Flowmeter. It ensures peak efficiency with the broadest range of wire spray coatings and operating conditions
- In the event of the slightest change in air line pressure to the gun, the Air Flowmeter provides instantaneous feedback to the system operator
- Spray rates can be easily adjusted, while in use, to meet unique parameters of specialized applications
- The Metco 4AC Air Cleaner can support six combustion spray guns simultaneously with clean, dry air
- Guns can accommodate a variety of wires and wire diameters with easy to change optional hardware
- The gun's universal gas head and burner system accommodates a variety of fuels, including acetylene, hydrogen, propane, MAPP, natural gas and propylene. A simple change to the gun's hardware (nozzle and/or siphon plug) is necessary when switching fuel sources
- The Metco 16E Wire Combustion Gun has a patented torque governor combined with a time-proven, controlled-power governor to assure the power you need is available when you need it
- Our Metco 16E Gun comes equipped with a patented safety handle, preventing injuries in the event the gun is accidentally dropped
- The Metco 6K Wire Combustion Gun is driven by a powerful constant-speed motor that provides precise control of wire speed and is ideally suited for automated production spraying



# Key Elements

## Building Blocks of a Successful Combustion Wire Spray Solution

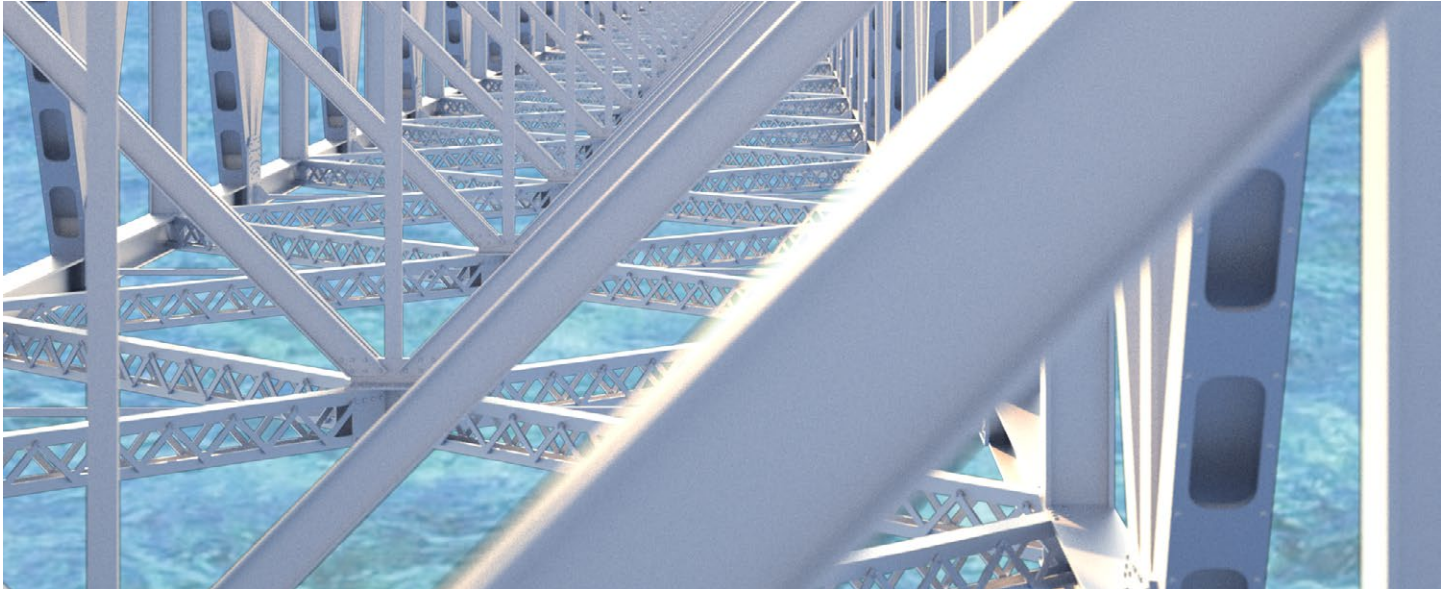

Structures such as bridges, towers, and tunnels receive vital protection from the elements through state-of-the-art wire combustion spraying.

**Key components:** Key elements are required for all combustion wire spray systems. These include the wire coating material to be applied, a wire control device to deliver the coating material to the spray gun, the combustion wire spray gun that will heat the coating material and propel it to the workpiece, and the means to accurately control the pressure and flow of oxygen, fuel gas and air required for combustion and for the air cap.

**Handling equipment:** While many combustion wire coatings are applied using simple manual systems, gun and workpiece handling equipment precisely controls the movement of the spray gun and workpiece, and the position of the gun relative to the workpiece, thereby improving coating repeatability.

**Peripheral equipment:** In-shop spray installations require a soundproof cabin and an air filtration and exhaust system protect both personnel and the environment. To ensure the highest possible coating quality, clean, dry, oil-free air is required.

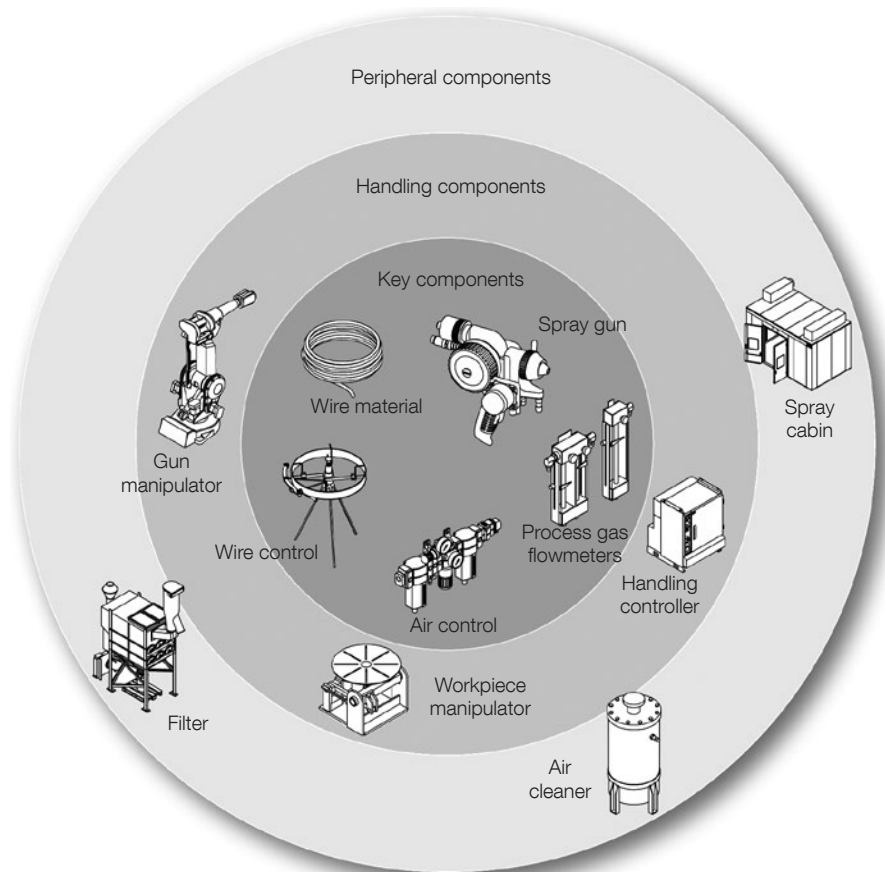

# Materials

## Every Successful Application Starts with the Right Material Choice

We offer a diverse portfolio of materials for the combustion wire spray process, each capable of achieving one or more surface functions. To further accommodate specific customer requirements, some of our wire materials come in several wire diameters. Many of our corrosion wires have multiple packaging options, such as coils or high volume drums.

Why should you source your combustion wires from Oerlikon Metco? The reasons are notable:

- Our diverse portfolio of products: we can help you choose and supply the material you need.
- Our quality and quality systems are certified to ISO 9001, ISO 14001, Nadcap, and by many of our major customers, as your assurance of the best possible material quality available.
- Our tightly controlled internal specifications means the materials we supply to you are of the highest reliability with excellent lot-to-lot consistency.
- Our in-house expertise, combined with our long, history of successful electric arc spray solutions.
- Our worldwide network of sales offices and hand-picked distributors, backed by our state-of-the-art logistics, means we can deliver, wherever your location and as fast as possible.
- Secure sources of supply and strong, long-standing supplier relationships ensure material availability.

Product	Base	Application Protection														
		Corrosion/Galvanic Protection	Erosion/Wear/Cavitation	Oxidation	Bio-Fouling	Bond Coat	Dimensional Restoration/Repair	Clearance Control	Chemically Strippable	Decorative/Cosmetic/Marking	Optical/Reflective	Electrical/Thermal Conductance	RFI/EMI Shielding	Gripper/Anti-Skid	Low Friction	Solderable
Metco Aluminum	Al	●		●			●		●	●		●	●			●
Metco SF Aluminum	Al						●				●					
Metco SF-NS Aluminum	Al						●				●					
Metco Copper	Cu	●			●		●		●	●		●				●
Sprabronze AA	Cu	●					●								●	
Sprabronze™	Cu	●					●				●				●	
Metcoloy 1	Fe		●				●								●	
Metcoloy 2	Fe		●				●								●	
Metcoloy 4	Fe	●					●									
Metcoloy 5	Fe	●	●				●									
Sprasteel 80	Fe		●				●									
Sprasteel 100	Fe						●									
Metco Nickel	Ni	●		●			●								●	
Metco 405-1	Ni			●		●										
Metco 405NS	Ni			●		●										
Metco NiCu (Monel)	Ni	●					●									
Metcoloy 33	Ni		●				●								◆	
Metco Silver	Ag															●
Metco Tin	Sn	●										●				●
Sprababbitt A	Sn														●	
Metco Zinc	Zn	●										●	●			●
Metco ZnAl	Zn	●										●	●			●

# Spray Systems

Ensure the Success of Your Application with the Right System

## Typical manual Combustion Wire Spray system

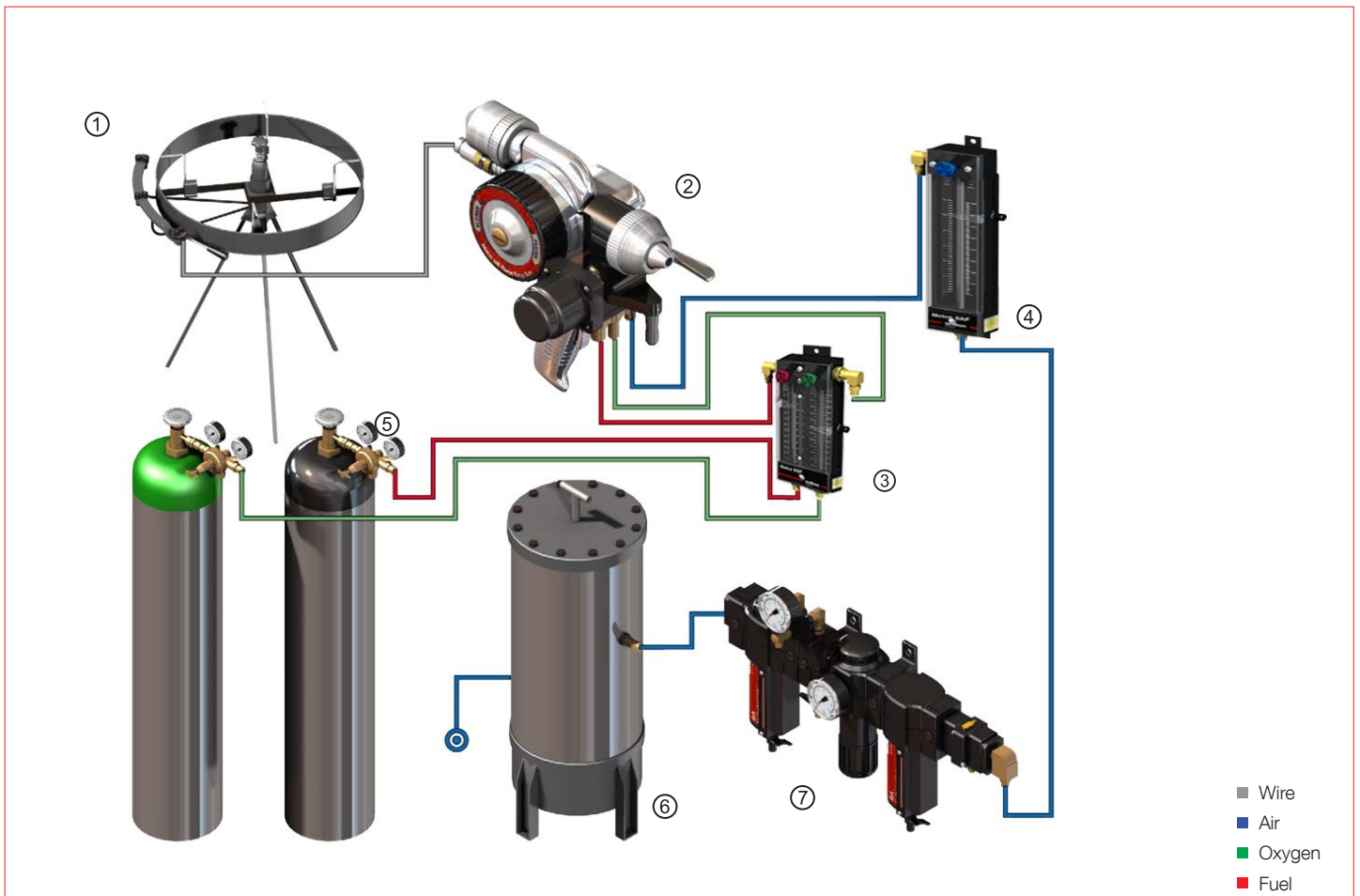

Only Oerlikon Metco has an equipment portfolio designed to meet your unique needs. Shown here are just a few examples of system configurations. Let our team of experts support you in designing your perfect system.

- 1. Metco 2W Wire Control Unit:** Essential for fast spray rates, this unit controls tension and straightens the wire as it uncoils, reducing wear on the gears, nozzle and wire guides.
- 2. Metco 16E Combustion Wire Gun:** A precision tool capable of applying coatings to a variety of surfaces. Optional, interchangeable hardware accommodates specific job demands. Equipped with safety handle.

- 3. Metco 5GF Gas Flowmeter:** Dual meters precisely control fuel and oxygen flows within  $\pm 5\%$  at any flow rate, and provide immediate indication of any supply line restrictions.
- 4. Metco 5AF Air Flowmeter:** This single-meter unit controls the flow of atomizing air and immediately indicates any air supply restrictions.
- 5. Oxygen and Fuel Gas Regulators:** With twin gauges to monitor cylinder and line pressure, and easy-to-adjust pressure handle. Supplied to local requirements.

- 6. Metco 4AC Air Cleaner:** Four-stage design provides optimal air purification and drying, with flow capacity to support six guns.
- 7. Metco 6A Air Control Unit:** With two filters and a large quarter turn valve cut-off, the 6A permits precise and rapid adjustment of air pressure to the 5AF Air Flowmeter.



# Spray Systems

Ensure the Success of Your Application with the Right System

## Typical semi-automatic Combustion Wire Spray system

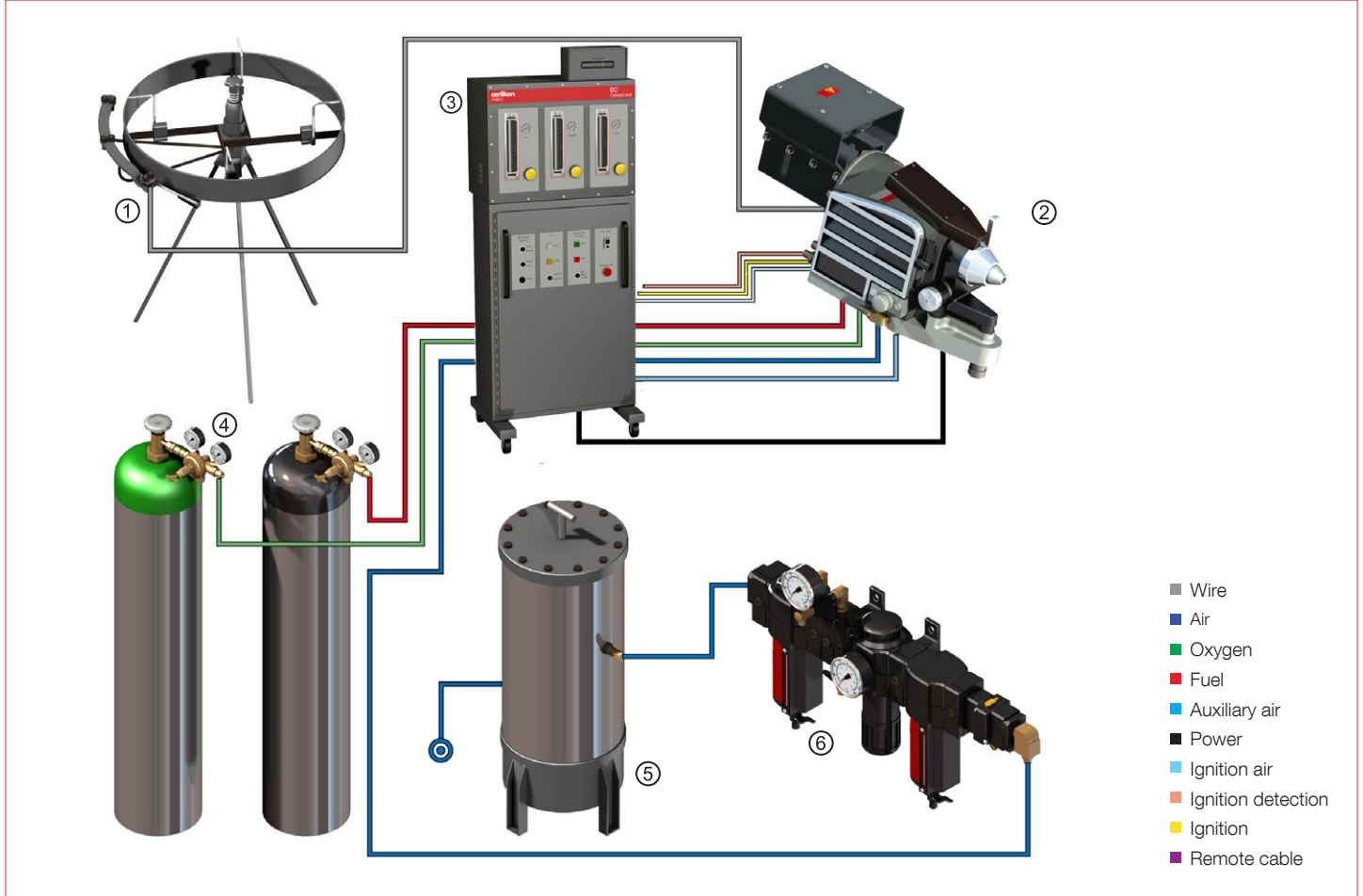

### 1. Metco 2W Wire Control Unit:

Essential for fast spray rates, this unit controls tension and straightens the wire as it uncoils, reducing wear on the gears, nozzle and wire guides.

### 2. Metco 6K/Metco 6K-A

**Combustion Wire Gun:** Ideal for short spray runs as well as complex, high-volume spray applications, the 6K/6K-A delivers optimum efficiency for denser, highly uniform, longer-lasting thermal spray coatings.

### 3. Metco 6C/Metco 6CEW Wire Combustion Control Unit:

With ease of use, this multi-gas compatible unit delivers superior coating quality, reduces operating costs and increases operational safety.

### 4. Oxygen and Fuel Gas Regulators:

With twin gauges to monitor cylinder and line pressure, and easy-to-adjust pressure handle. Supplied to local requirements.

**5. Metco 4AC Air Cleaner:** Four-stage design provides optimal air purification and drying, with flow capacity to support six guns.

**6. Metco 6A Air Control Unit:** With two filters and a large quarter turn valve cut-off, the 6A permits precise and rapid adjustment of air pressure to the 5AF Air Flowmeter.

# Spray Systems

Ensure the Success of Your Application with the Right System

## MultiCoat™ Advanced Automated Wire Combustion Spray system

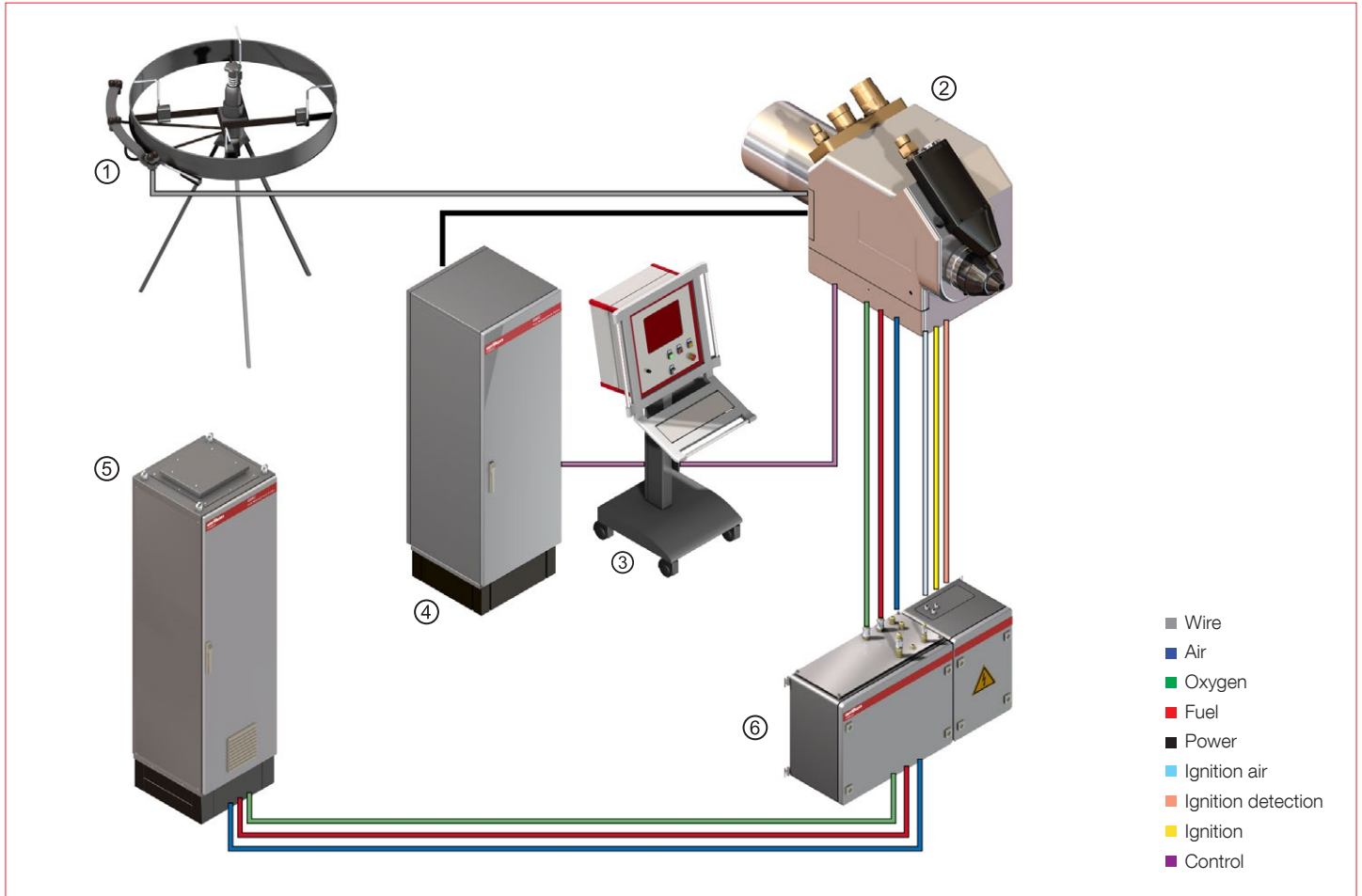

### 1. Metco 2W Wire Control Unit:

Essential for fast spray rates, this unit controls tension and straightens the wire as it uncoils, reducing wear on the gears, nozzle and wire guides.

### 2. Metco EGD-K Combustion

**Wire Gun:** Designed for use with Oerlikon Metco's advanced, fully-automated system platforms, the EGD-K has closed-loop control and communication with the system to provide the ultimate in uniform wire and process gas delivery. As a result, efficiency is maximized and coating quality ensured.

### 3. MultiCoat Operator's Desk:

An industrial-quality PC-based user interface that allows easy input, storage, monitoring and management of the entire coating process using object-oriented, on-screen graphics. Allows recall of spray recipes and related customer-defined data from memory. System diagnostics and alarms are displayed on-screen for rapid intervention by the operator.

### 4. Process Control Center:

The brain of the system that contains all electrical controls, including the PLC and system safeties. It controls the entire spray process in real time and collects process data as well as fault messages.

### 5. Gas Management Center:

Using proven mass-flow controllers, this unit controls the delivery of all system process gases with high precision and safety.

### 6. JAMBox:

A centralized junction and monitoring device for the system, the JAMBox houses the sensors to detect measured values electric current, process gases and wire speed. Using transducers, it communicates the measured values to the Process Control Center via a serial data bus.



# Flexible Choices

## Combustion Wire Spray Guns and Extension Modules

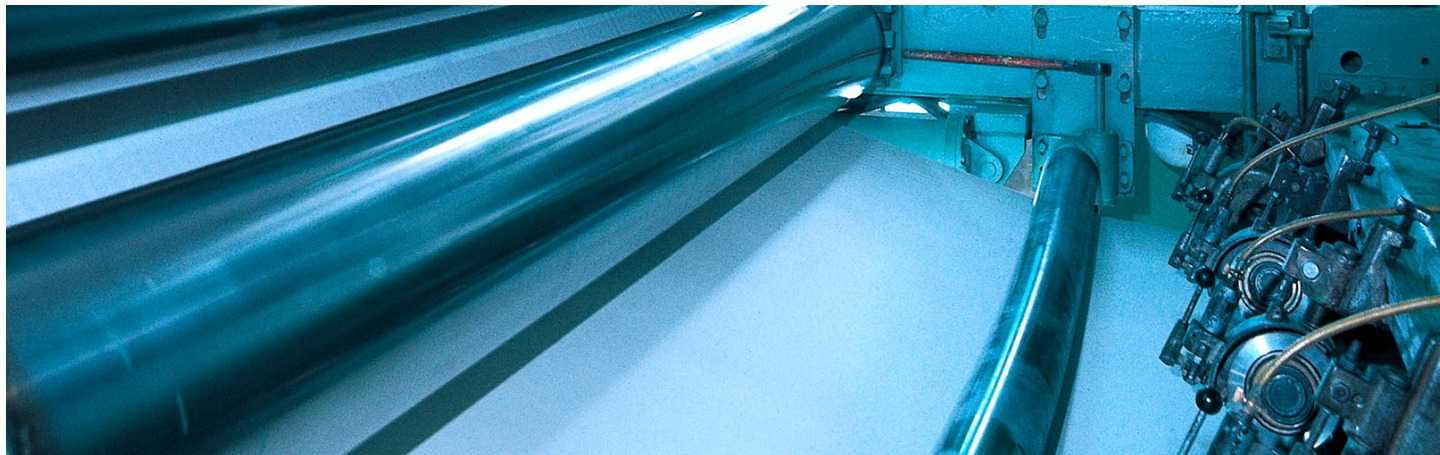

Utilized in the paper, pulp and printing industries, combustion wire spray increases component efficiency and lifetime.

### 16E Handheld Spray Gun



16E

### 5K Machine-Mount Spray Gun



6K

6K-A

### Extension modules for coating of internal surfaces



5XT

3XT-1

#### Available models

Model	Fuel Gas <sup>a</sup>	Speed	Wire Type
16E	Acetylene	Standard	Hard wires
16E-H	Acetylene	High	Soft wires
16E-HT	Propylene/ Propane	High	Al, Zn, Zn-Al
16E-P	Propane	Standard	Hard wires

- Unique built-in safety handle
- Rugged and low maintenance
- Gun can operate in any position
- Lightweight and comfortably balanced
- Low gas consumption, even at high spray rates
- Powerful air turbine motor – no electricity
- Superior resistance to jamming and backfiring
- Versatile optional hardware for a variety of coating needs with quick changeovers

#### Available models

Model	CE Conformance	Controller
6K	Yes	6KC
6K-A	Yes	6C/6CEW
EGD-K	Yes	MultiCoat

- Durable with very stable operation
- Constant motor control over a wide range for uniform wire feed
- Optimized spray efficiency denser, highly uniform, longer lasting thermal coatings
- For short spray runs as well as complex, large scale production
- Dynamic braking system stops wire feed immediately
- Motor can be turned off and on without altering speed settings
- Compact control system mounts directly onto gun for easy wire feed adjustment
- Versatile optional hardware for a variety of coating needs with quick changeovers

#### Available models

Model	Length
5XT	150 mm (6 in)
3XT-1	305 mm (1 ft)
3XT-2	610 mm (2 ft)
3XT-3	915 mm (3 ft)

- Ideally suited for spraying internal bores and diameters
- Applies high quality coatings
- Designed for use with all Oerlikon Metco Combustion Wire Spray Guns and wire sizes
- Standard configuration uses acetylene fuel gas; configurations for other fuel gases available on request

<sup>a</sup> As equipped at factory. Optional hardware available for different gases.

# Flexible Choices

## System Platform Choices That Suit Your Operations

### Manual

#### Metco 5AF / Metco 5GF

The ultimate in simplicity! Accurately set gas flows using the 5GF gas flowmeter and 5AF air flowmeter in either NLPM or SCFH units. These units are easily hung on the wall in the acoustical enclosure at eye level for operational convenience. Should be used in conjunction with the Oerlikon Metco 6A air control unit.

**Recommended for:** For occasional coating work by budget conscious operations using a limited number of spray parameters on non-critical components.



### Semi-automatic

#### Metco 6C / Metco 6CEW (CE)

In addition to providing convenient semi-automatic operation, monitoring, and control of the Metco 6K or Metco 6K-A gun, the Metco 6C and Metco 6CEW are multi-gas-compatible units capable of operating with all fuel gas options and gas parameters. Designed to withstand the rigorous demands of modern production and job shop environments, it's easy to use and maintain, delivers excellent coating efficiency and quality, and reduces operating costs, while increasing operational safety.

**Recommended for:** Production spray operations using a limited number of spray parameters.



### Advanced

#### Oerlikon Metco MultiCoat

An advanced system platform, MultiCoat employs a "twin brain" PC/PLC design to ensure superior accuracy and repeatability. The operator console simplifies data entry and recall and a generous recipe storage capability guarantees precision parameter recall again and again. MultiCoat system platforms have multi-level diagnostics and alarm systems, and built in parameter drift limits.

**Recommended for:** Production or R&D spray operations where precision and accuracy are critical.





# Flexible Choices

## Accessories, Handling and Peripheral Equipment

### Accessories



Standard Tools and Lubricants  
(provided with spray gun)



Standard Safety Kit

### Oerlikon Metco handling equipment

Customize your spray system with gun and part manipulation equipment from Oerlikon Metco that includes robotic manipulators, turntables, vertical and horizontal traverses and more.

Specialized handling requirements? No problem! We can custom design, fabricate and test exactly what you need.



Turntables



Robotics

### Oerlikon Metco peripheral equipment

Oerlikon Metco has everything you need to complete your thermal spray solution, including the necessary components to meet even the toughest of environmental regulations.



Spray Booths

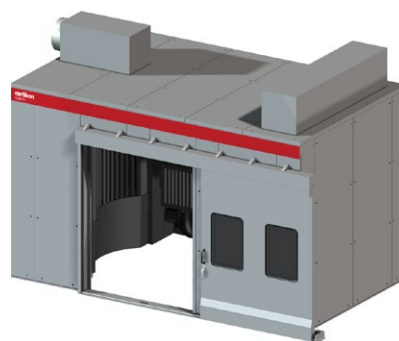

Acoustical Enclosures



Traverses



Filtration Units

# Roadrunner

## Wire Combustion Spraying That's Going Places ...



The Roadrunner, our leading-edge mobile wire combustion thermal spraying system, is compact and easy to operate.

With the remarkable Roadrunner™ mobile wire combustion spray system, Oerlikon Metco has opened up a whole new world of opportunities. The only mobile system of its kind that's all-terrain, the Roadrunner makes maintenance and repair projects once impossible not only achievable, but profitable.

Compact and easy-to-operate, this is a complete, self-contained transportable wire combustion system designed to handle a heavy-duty workload. Built with top-quality, time-proven Oerlikon Metco components, the Roadrunner is equally functional in-shop or in remote field locations. For maximum convenience and flexibility, Roadrunner can be ordered with Metco 16E Wire Spray Gun model of your choice.

Included with every Roadrunner Mobile System:

- Roadrunner wheeled cart
- Choice of Metco 16E Combustion Wire Spray Gun
- 5GF Gas Flowmeter
- 5AF Air Flowmeter
- 6A Air Control Unit
- Fuel and oxygen regulators
- Hose kit
- 2W Wire Stand (attached to the Roadrunner cart)
- Gun holding bracket

Already have a Oerlikon Metco wire combustion system? We can supply you with the Roadrunner mobile cart prepared to accept your existing wire spray components.



Roadrunner Mobile Wire Combustion Spray System (Hoses not shown; gas cylinders not included)



# Services

## Oerlikon Metco Essential Services for On-Going Success



### Training

Let our staff professionally train your personnel on the safe operation and maintenance of your thermal spray systems.



### Field service

Qualified, factory-trained field service technicians will keep your systems in peak operating condition. Our field services include flexible maintenance contracts, emergency break-down repairs and troubleshooting help.



### Traceability

Fully traceable calibrations, including gas flows and pressures, ensure the accuracy and repeatability of your spray facilities.

### Application consultation services

Our thermal spray professionals can consult with you for a total application solution with optimized benefits and value.



### Consumable and spare parts support

Oerlikon Metco brand consumable and spare parts keep your coating facilities operating with repeatable results.

### Simplified sourcing

Simplify your purchasing decisions with Oerlikon Metco quality consumable parts, materials and after-sale services.

### Global sales and logistics

Oerlikon Metco professionals are prepared to help, wherever your location.

### Make or buy – it's your decision

If you would prefer to outsource your coating work, Oerlikon Metco is ready to serve you. We have first-rate coating facilities on every major continent around the globe. The surface engineering experts at the Oerlikon Metco coating service facility of your choice are ready to consult with you and provide your company with expert coating and machining services.

# Combustion Wire Spray

## Advanced technology solutions and services



**Combustion  
Wire**

### Perfect solutions through optimum materials and innovative technologies

Oerlikon Metco is a global leader in surface engineering solutions and services offering:

- A broad range of thermal spray and other advanced surface technology equipment and materials
- Integrated systems
- Specialized coating and surface enhancement services
- Customer support services

Oerlikon Metco provides a comprehensive manufacturing, distribution and service network, catering to aviation, power generation, automotive and other strategic growth industries.

To take control of your surface engineering challenges, contact your Oerlikon Metco sales office, visit our website at [www.oerlikon.com/metco](http://www.oerlikon.com/metco) or email us at [info.metco@oerlikon.com](mailto:info.metco@oerlikon.com)

### About Oerlikon Surface Solutions Division

Oerlikon is a leading global provider of surface and additive manufacturing solutions and services. The division offers an extensive portfolio of market-leading thin-film, thermal spray and additive manufacturing technologies, equipment, components and materials. Emission reduction in transportation, maximized longevity and performance of tools and components, increased efficiency and intelligent materials are hallmarks of its leadership. Pioneering technology for decades, the division serves customers with standardized and customized solutions across a worldwide network of more than 170 sites in 37 countries.

With its technology brands – Oerlikon Balzers, Oerlikon Metco, Oerlikon AM, Oerlikon Riri and Oerlikon Fineparts – the Oerlikon Surface Solutions division focuses on technologies and services that improve and maximize performance, function, design, reliability and sustainability, which are innovative, game-changing advantages for customers in the automotive, aviation, tooling and general industries and in the luxury, medical, semiconductors, power generation and oil & gas markets.

The division is part of the publicly listed Oerlikon Group (SIX: OERL), headquartered in Switzerland, which has 12,600 employees and generated CHF 2.7 billion in revenue in 2023.

For more information see: [www.oerlikon.com/surface-solutions](http://www.oerlikon.com/surface-solutions)

Information is subject to change without prior notice.