

**oerlikon**  
metco

# MultiCoat Pro

Advanced Thermal Spray System Platform

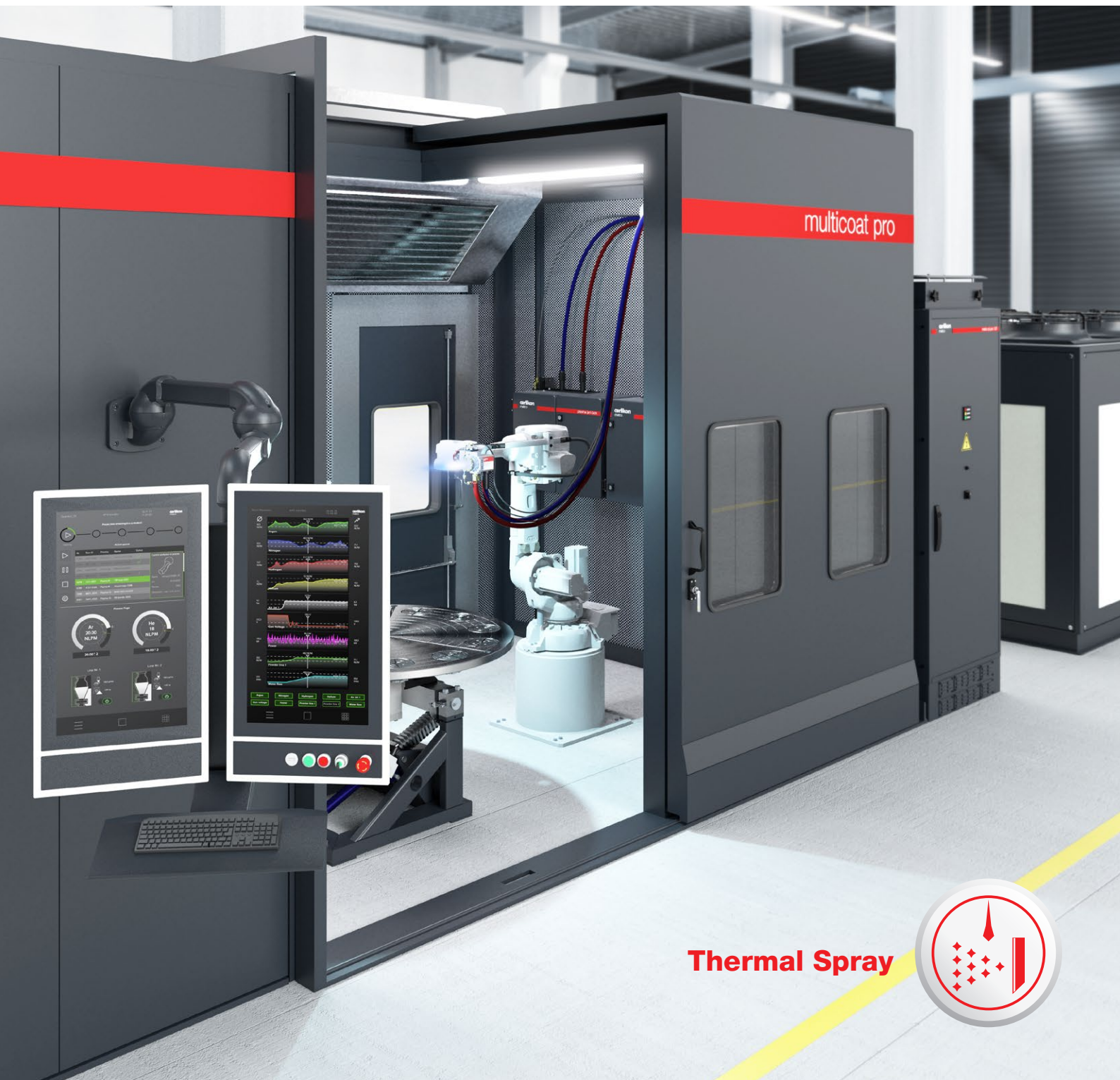

**Thermal Spray**



# Fully adaptable

## Full control

When the Oerlikon Metco MultiCoat™ system platform was introduced in 1995, it redefined the thermal spray process. Today, it is widely considered the industry standard. With the development of our next-generation MultiCoat Pro system platform, we took great care to ensure our customers receive the same reliability and repeatability they expect while improving efficiency, flexibility and usability.

### **Benefit from unlimited versatility and unmatched process control delivered by the Oerlikon Metco MultiCoatPro system platform:**

- MultiCoat Pro's new Clarity User Interface with Production Manager is a leap forward for efficiency and ease of use.
- Ensure full production flexibility by integrating multiple thermal spray processes into one MultiCoatPro system platform.
- Significantly increase utilization rate on your shop floor and benefit from lower overall capital investment by combining several spray booths into one.
- Easily adapt to changing requirements and upgrade your processes thanks to full modularity of hardware and software.
- Boost your productivity and minimize the chance of errors with improved usability and operator guidance.
- Be ready for the smart factory of the future with Industry 4.0 / Industrial Internet of Things (IIoT) capability.

**multiple  
thermal spray  
processes in  
one system  
platform**

**Handle up to five separate atmospheric thermal spray processes using one MultiCoat Pro system and operator console or a controlled atmosphere process.**

- Atmospheric plasma spray (single and triple cathode guns)
- Controlled atmosphere plasma spray
- HVOF gas fuel spray
- HVOF liquid fuel spray
- Combustion powder spray
- Combustion wire spray



**Plasma**



**ChamPro**



**HVOF**



**Combustion**





# Handle parts your way with unlimited handling options

- Choose the spray gun and part handling systems that best suit your production requirements.
- Benefit from Oerlikon Metco's vast experience in integrated handling systems that are both efficient and safe.
- Select from the most popular robotic systems that you already use in your production.
- Consider dual handling stations to process parts of varied size and geometries in one spray booth, maximizing the MultiCoat Pro's utilization rate.

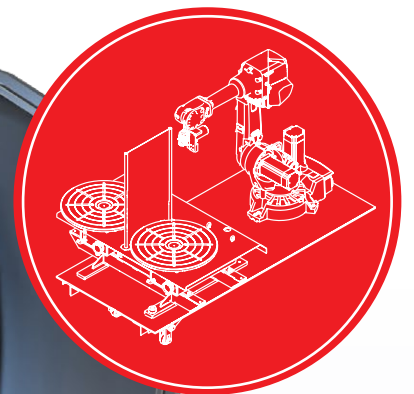
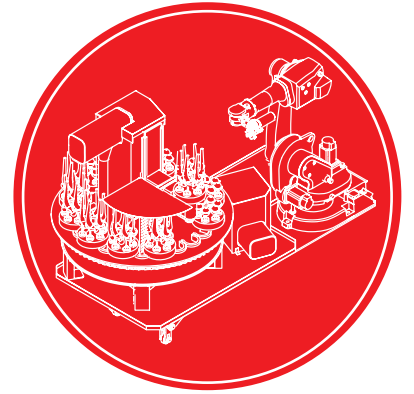
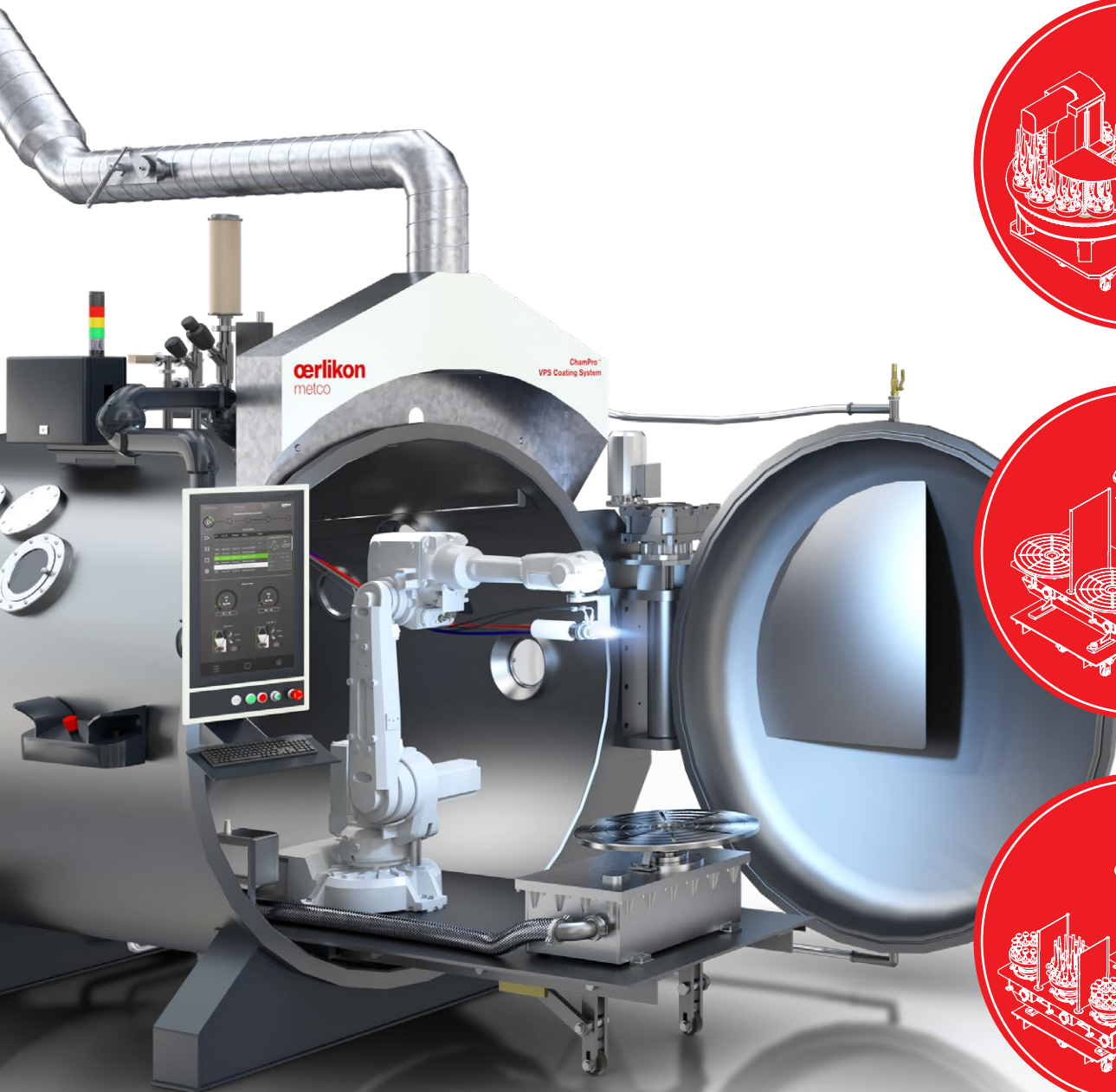

# Maximize process reliability and availability

- Time-consuming, error-prone part changeover and operational handling is a thing of the past — our unique Clarity user interface makes controlling your entire production coating process as easy as plug and spray.
- Ensure consistent production quality thanks to integrated recipe storage and recall.
- Increase system availability by managing recipes and production processes remotely from your computer or a tablet without interrupting production.
- Benefit from consistent powder feed rates thanks to closed-loop gravimetric feed control and more responsive and reliable digital mass flow controllers.

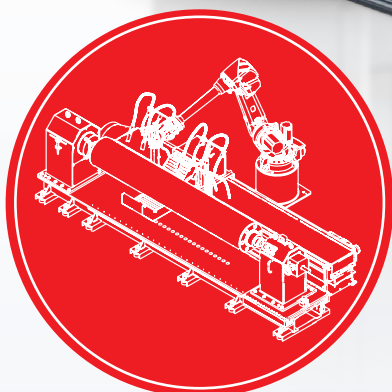
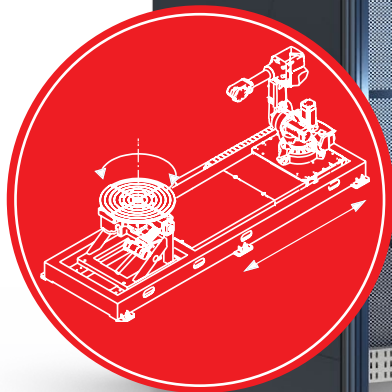
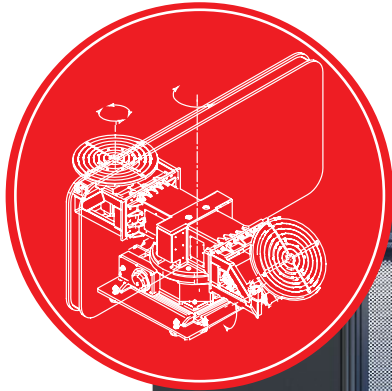

# Spend more time on your product and less on operating issues

At the heart of the MultiCoatPro system platform lies the Clarity user interface and Production Manager. Clarity is designed to simplify your production process and enable an easier, faster and more efficient operation. Benefit from the intuitive, customizable user interface and integrated operator guidance.

- Clarity reduces complexity and focuses on the information relevant on the task. This eliminates operating errors, improves productivity and minimizes training effort.
- Key process indicators are designed for fast and intuitive recognition. The large, high-contrast display makes indicators visible from a distance so operators can multitask and spend their time more effectively.
- First time right — Clarity allows you to design the way your parts should be coated with step-by-step instructions that guide the operator through the entire process.



## Full control

The intuitive process interface is easy to use and provides updates on the status of all relevant data at a glance.

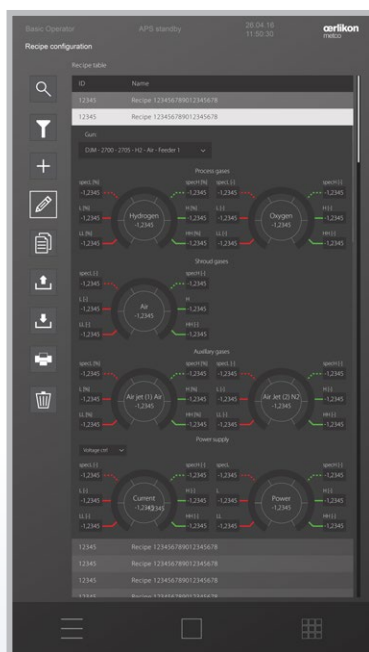

## Easy setup

Operators are guided through the production setup of appropriate thermal spray and motion control recipes to achieve the perfect coating.

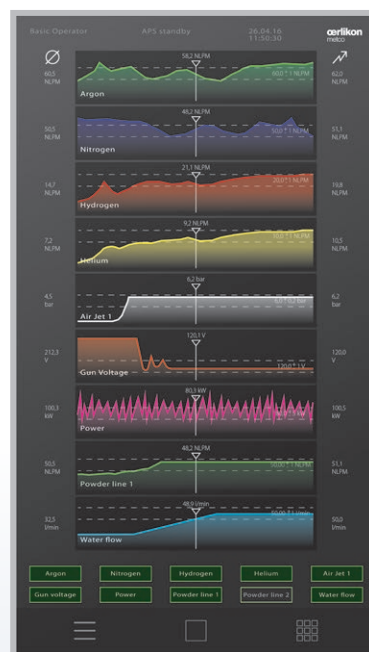

## Continuous optimization

Quick access to easily readable process data enables informed decision-making and continuous process improvements.



# Keep your process running

Maximize your productivity and minimize interruptions to the production process by accessing sophisticated multi-level alarm and maintenance information.

- Clarity helps optimize your resources. It keeps you informed by diagnosing system performance and lets you know when maintenance is needed.
- Integrated system diagnostics help maximize your uptime. They immediately alert you to malfunctions with detailed error reports so you can intervene fast and efficiently.

# Stay in control and move ahead

With Clarity, you are fully connected and in control — and able to remain a step or two ahead of your competitors!

- Quickly scale up and replicate production by simply transferring coating recipes and operating configurations from one MultiCoat Pro system to another regardless of location.
- Easily integrate Clarity into your production environment to improve control of the production process and increase productivity.
- With Clarity, your coating process has Industry 4.0 and IIoT features that provide real-time status information about the manufacturing process and system health.



# MultiCoat Pro

## Advanced Technology Solutions and Services



**Thermal  
Spray**

### **Perfect solutions through optimum materials and innovative technologies**

Oerlikon Metco is a global leader in surface engineering solutions and services offering:

- A broad range of thermal spray and other advanced surface technology equipment
- Integrated systems and materials
- Specialized coating and surface enhancement services
- Customer support services

Oerlikon Metco provides a comprehensive manufacturing, distribution and service network, catering to aviation, power generation, automotive and other strategic growth industries.

To take control of your surface engineering challenges, contact your Oerlikon Metco sales office, visit our web site at [www.oerlikon.com/metco](http://www.oerlikon.com/metco) or e-mail us at [info.metco@oerlikon.com](mailto:info.metco@oerlikon.com)

### **About Oerlikon Metco**

Oerlikon Metco enhances surfaces that bring benefits to customers through a uniquely broad range of surface technologies, equipment, materials and turnkey coating services. Furthermore, we offer a flexible portfolio of customer support services tailored to the needs of our clients. As the leader in thermal spray, we improve the performance, efficiency and reliability of our customers' components and systems. In addition to thermal spray, we also supply materials for additive manufacturing, conductive fillers for the electronics industry and other critical industrial processes. Oerlikon Metco serves industries such as aviation, power generation, automotive, oil & gas, industrial and other specialized markets and operates a dynamically growing network of more than 50 sites in EMEA, Americas and Asia Pacific. Oerlikon Metco, together with Oerlikon Balzers and Oerlikon AM, belongs to the Surface Solutions Segment of the Switzerland-based Oerlikon Group.

Information is subject to change without prior notice.