

Manual DTY (PET)

Technical data

Dimensions Manual machines

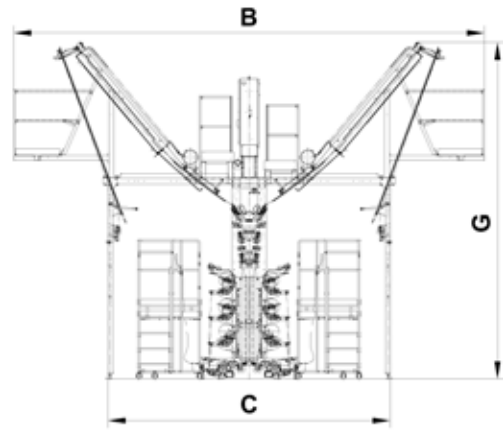

eFK-Standard

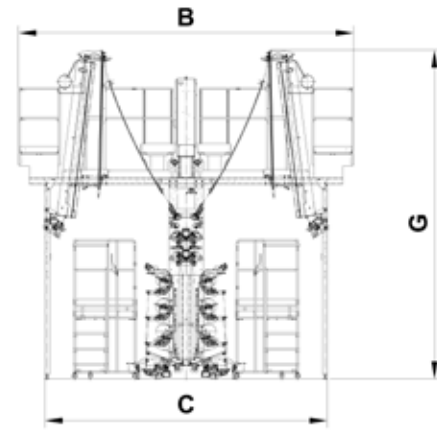

eFK-Coarse

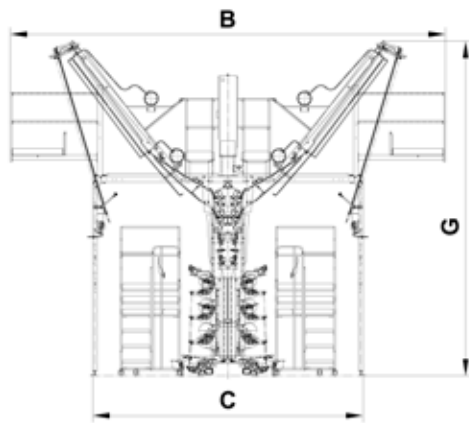

eFK-Multi

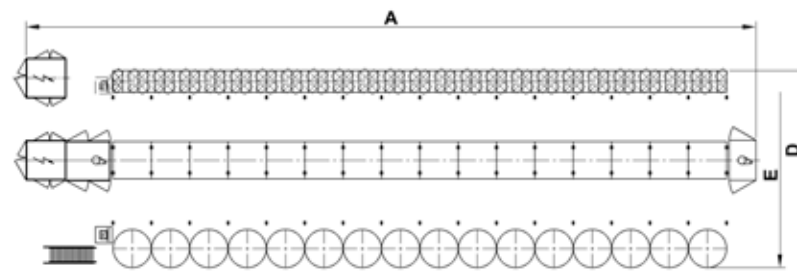

eFK Site plan

Technical data manual machines

Name		Standard	Coarse	Multi
Machine		eFK		
Main product		PET		
Type		Single	Single	Multi
Cross section		V	M	V
Machine product range	[den]	30-300D	100-450D ¹⁾	2 x 30-300D
Preferred operational range	[den]	50-200D	150-300D	2 x 50-200D
Basic Machine Configuration				
Number of sections		16	16	16
Take-up positions per machine		384	384	384
Mechanical speed potential	[m/min]	1200	1200	1200
Heating and cooling system				
Primary heater type		Diphyl	Diphyl	Diphyl
Primary heater length	[m]	2.0	2.5	2.0
Cooling type		Rail	Rail	Rail
Cooling length	[m]	1.1	2.1	1.1
Secondary heater length	[m]	1.46	1.46	1.46
Feed system				
Godet / Shaft		G1/G1.X/G2/G2X or W1/W1.X/W2/W2X	W1/W1.X/W2/W2X	G1/G1.X/G2/G2X or W1/W1.X/W2/W2X
Feed before take-up		W3		
Take-up system				
Take-up concept		ATT or Camshaft		
Max package stroke	[mm]	250		
Max package diameter	[mm]	250		
Nominal taper angle	[°]	67-90 (ATT) or 65-90 (Camshaft)		
Power data				
Power connection	[V]	380 [≥ 415 with transformer]		
Frequency	[Hz]	50 (60)		
Dimensions				
Length overall (A) ²⁾	[mm]	27406	27406	27406
Width overall top of Machine (B)	[mm]	7944	5650	7668
Width overall bottom of machine (C)	[mm]	4764	4764	4764
Width overall with stationary creel (D)	[mm]	6724	6724	\
Width overall with rotary creel (E)	[mm]	8074	8074	8820
Height (G)	[mm]	5678	5549	5894
Section pitch	[mm]	1440	1440	1440
Yarn pitch	[mm]	110	110	110

¹⁾ Machine Product range 300-450D, should with type 8E Friction Unit and with 1.4:1 transmission ratio
²⁾ Considering maximum number of sections