

Product Data Sheet Metco 9MBM Plasma Spray Gun

Engineered for reliable, top-of-the-line performance, the Metco™ 9MBM plasma gun masters the possibilities of the plasma spray process to produce high quality coatings that exceed market demands and specifications.

Designed and constructed with high performance hardware, the 9MBM plasma gun provides high kW range capability and offers extended component service life. The gun has been carefully engineered to achieve optimum heat transfer through uniform distribution of the cooling water within the nozzle. Extending the life of critical plasma gun components translates into decreased downtime, increased productivity, reduced maintenance and lower operating costs.

The Metco 9MBM plasma gun is designed and engineered with safety as an important element. Through extensive research and development, coupled with many years of experience, Oerlikon Metco has forged a system of reliable, safe plasma spray equipment, processes and procedures. When safety recommendations and specifications are followed, Oerlikon Metco's equipment can be utilized with complete confidence.

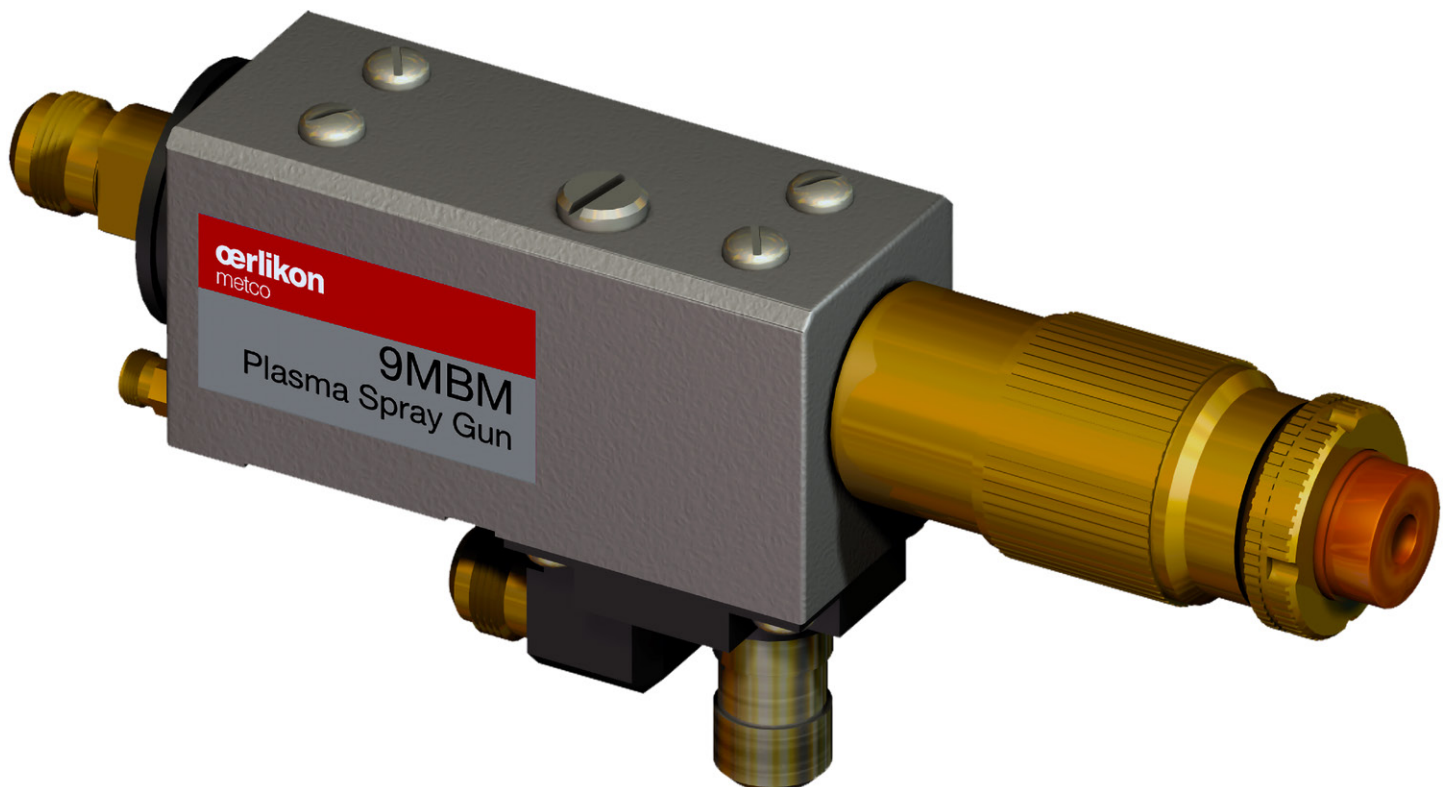

Metco 9MBM Plasma Spray Gun

1 General Description

The Metco 9MBM hardware was designed by Oerlikon Metco for versatile, safe and easy operation. When changing from one spray material or plasma gas to another, the switch-over is fast — nozzles and electrodes are plug-in/pull-out assemblies.

Water-cooled power cables for the gun have a right- and left-hand thread design, making it impossible to cross-connect them. Heavy plastic insulators are provided to protect the operator from electrical shock.

The automatic plasma control unit ignites and shuts down the Metco 9MBM gun, monitors and controls the arc current, the gun cooling water, and the plasma gas flow, according to

preset parameters.

The Metco 9MBM was designed to operate efficiently with power levels up to 80 kW, (80 V @ 1000 A) in continuous operation mode (100 % duty cycle). When operating with the Metco 9MC plasma control unit, gun voltage is measured directly at the Metco 9MBM gun for improved parameter accuracy.

The Metco 9MBM plasma gun is capable of operating efficiently with a single primary gas of pure argon or nitrogen and with multi-gas parameters of argon, nitrogen, hydrogen and helium.

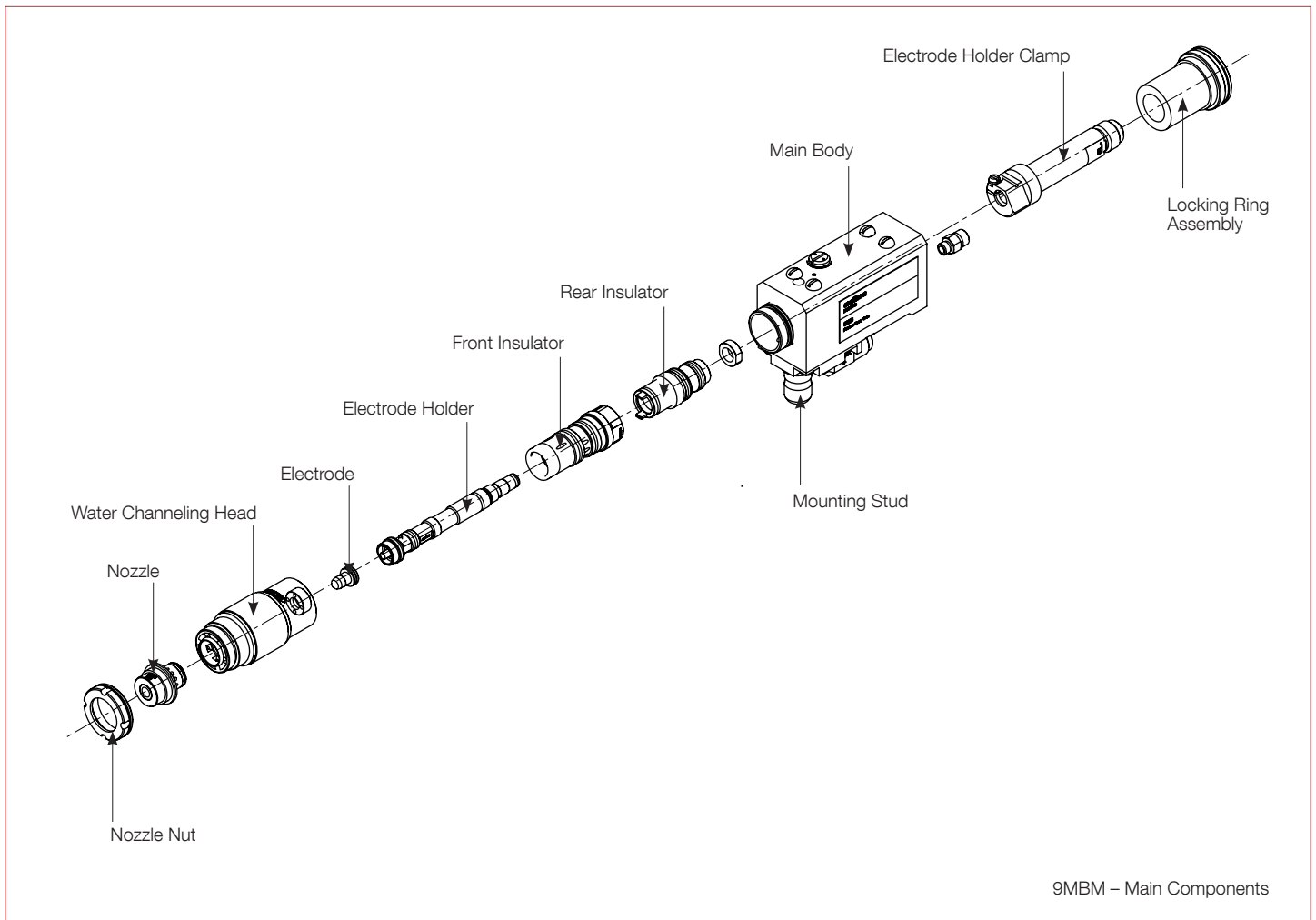

2 Features and Benefits

- High power capability: optimum performance at levels up to 80 kW
- High heat output capabilities: plasma gas temperatures up to 16,000 °C (28,880 °F)
- High plasma gas velocity: in excess of 3,050 m/s (10,000 ft/s).
- Dual Gas Capability: operates with either argon or nitrogen as the primary plasma gas.
- High Particle velocities: up to 610 m/s (2,000 ft/s)
- Nozzles designed with Thin Annular Passage Cooling (TAP): precisely direct the cooling water for optimum heat transfer and even distribution within the hardware.
- The design of the electrode allows for impinged water cooling to be directed into the critical tungsten tip area, resulting in improved electrode life.
- Long life gas insulators: fabricated from heat-resistant ceramics, ensure durability and uniform gas flow at high power levels.
- Modular construction: permits the use of high perfor-

- mance hardware.
- Adaptable with extensions: allows for internal diameter spraying (e.g., cylinder walls), or for spray applications in hard-to-reach areas.
- Improved hardware accessibility: allows easy replacement and changeover of nozzles, electrodes and gas insulator assemblies.
- High power levels: extended nozzle and electrode life.
- Higher spray rates: shortens production time.
- Advanced technology: broadens range of capabilities.
- Ease of operation, maintenance, and installation: ideally suited for general purpose and advanced coating applications
- Operates with: SCR-controlled power supply units
- Historically proven nozzle design: offers economical replacement cost.
- Fully operational with nitrogen as the primary fuel gas: economical operating parameters with high heat energy output.

3 Accessories and Options

A wide range of accessories and optional parts are available for the Metco 9MBM plasma spray gun:

- Gun Extension Modules

Type	Length	Minimum Bore Diameter
7MT-2	457 mm (18 in)	57 mm (2.25 in)
7MST-2	502 mm (19.75 in)	51 mm (2 in)

- Workpiece Cooling
- Quad powder port air jet assembly – holds up to four powder ports and provides air jet cooling to workpiece.
- Machine Mounts for extensions
- Right-angle Cable Connections
- Hoses and Cables
- Mounting Stud
- Tool Post
- Gun Hook/Suspension
- Cable Support

For a complete list of optional parts and spare parts please refer to the parts lists section of the reference manual.

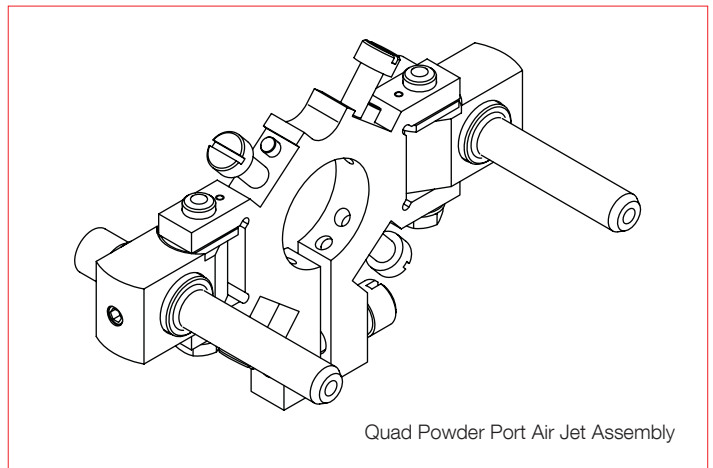
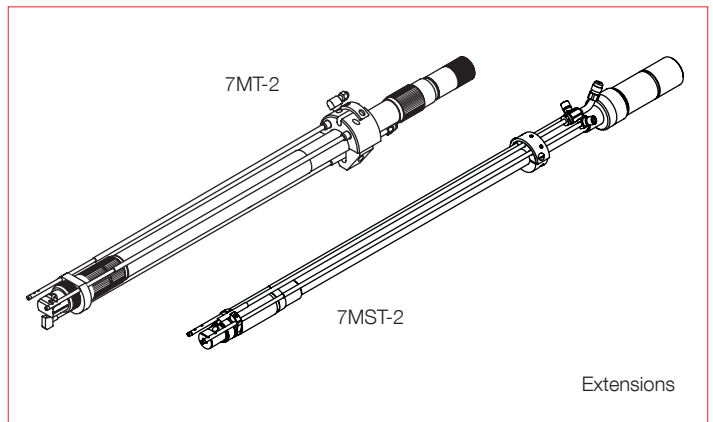

4 Technical Data

4.1 Dimensions

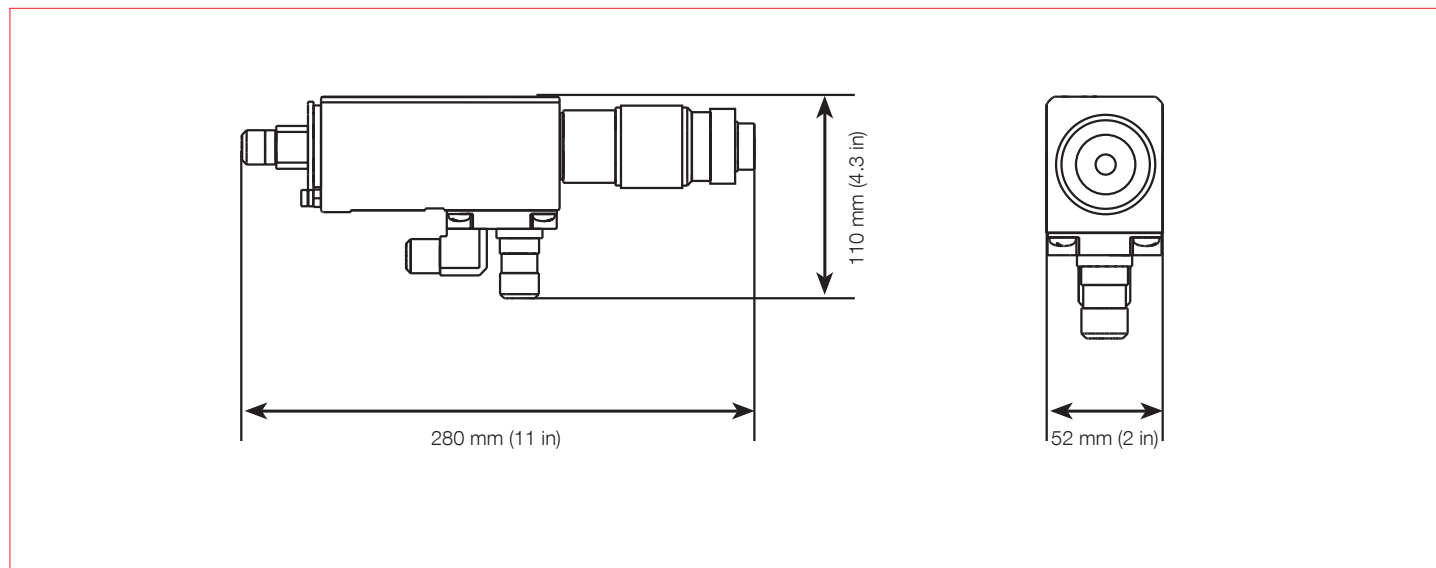

4.2 Specifications

Power rating

Maximum 80 kW

Weight

without hoses and cables 3.6 kg 7.9 lb

Cooling Water

Inlet temperature < 18.3 °C < 65 °F

Inlet pressure 8.7 to 9 bar 125 to 130 psi

Flow 14 to 17 l/min 3.7 to 4.5 gal/min

Quality

Conductivity < 5 μ S/cm

ph Value 6.6

Deposite Efficiency

Typical < 75 %

Spray rate

Typical < 75 g/min < 10 lb/hr

Plasma Controller

Compatible with all Oerlikon Metco plasma controllers

Powder Feeder

Compatible with all Oerlikon Metco powder feeders

Information is subject to change without prior notice.

5 Life-Cycle Status and Support Options

Our four-phase life cycle model keeps you informed about available services and support options throughout the life span of your equipment



5.1 9MBM Status

- Current Life Cycle Status: Active
- Inception Date: March 2010

During the Active phase, you have our full support and range of services. Using our life-cycle services will keep your equipment in the best operating condition

5.2. Keeping You Informed

We will notify you early and transparently about your options as your equipment enters into the next life-cycle phase, providing your equipment is registered with Oerlikon Metco

5.2.1. Life-Cycle Notification

Provides early information about the upcoming life-cycle phase change and how your equipment can be best supported.

5.2.2. Life-Cycle Status Statement

Provides information about the current life-cycle status and all available options and services to maintain your equipment in best condition.

5.3. The Oerlikon Metco Difference

Benefit from our selection of comprehensive services designed to ensure:

- Consistent spray quality, with little to no parameter shift
- Compliance with your ISO quality requirements
- Maximized equipment uptime
- Extended overall equipment lifetime
- Fast availability of spare parts

5.4. Your Best Value for Peak Performance

Choose from our broad portfolio of services to keep your equipment in top condition now and in the future

- Spare parts
- Preventive maintenance
- Repair Service
- Customer training

Take advantage of an Oerlikon Metco Service Agreement tailored to your specific needs!

For more information on your service and support options, please contact your Oerlikon Metco Account Manager.