

Product Data Sheet

SinplexPro 03C Cascading Arc Spray Gun for ChamPro Controlled Atmosphere Plasma Spray Systems

SinplexPro™ 03C Plasma Spray Gun is designed for your chambered plasma spray process and is the perfect choice for new systems or as a replacement for an existing spray gun.

The SinplexPro 03C Plasma Spray Gun combines the benefits of cascading arc design with the simplicity of a single-cathode.

Effective

With its cascading arc design, the SinplexPro 03C brings a new concept for low pressure ChamPro™ (chambered plasma spray) operations, including VPS, LPPS™ and LVPS™ spray systems. The coatings produced are of excellent quality. The SinplexPro 03C also offers exceptional operational stability over a large operating window, even with argon-only spray parameters.

This makes SinplexPro 03C the best choice for new ChamPro systems. However, customers with existing ChamPro systems and older, conventional 03C spray guns will be pleased to know that the SinplexPro 03C can be used without any additional system hardware changes.

Efficient

The constant energy state produced by the SinplexPro 03C gun provides very efficient heating conditions in the plasma stream resulting in highly reproducible processing.

Economical

Like non-cascading spray guns used in chambered plasma spray systems (i.e., 03C series and F4VB), the SinplexPro 03C spray gun can operate using binary (Ar/H₂; Ar/He) or ternary gas combinations (Ar/H₂/He). However, non-cascading spray guns require the use of binary or ternary gases to achieve the necessary output power, the SinplexPro 03C can operate very effectively and achieve power levels up to 100 kW using argon-only parameters. The capability to operate without hydrogen improves operational and facility safety. Operation without expensive helium can reduce overall processing costs. In addition, argon-only parameters generally reduce the wear of the spray gun components, thereby lowering the overall cost of gun consumable parts and resulting in longer operation before the need for part changeover.

When binary gas parameters are used with the SinplexPro 03C spray gun, the secondary gas requirements are lower than those required for non-cascading spray guns to achieve high power output.



SinplexPro 03C

The SinplexPro 03C spray gun produces the desired coating at significantly lower power input to achieve the same net power as the legacy Oerlikon Metco 03CP spray gun. In fact, for some operations, current reduction of nearly 40% could be achieved, representing a significant cost savings for large-scale series production. Many operators will find their coating needs can be achieved using only a single 100 kW power supply.

The SinplexPro 03C will provide economical benefits whether the plasma operating conditions are for short spray runs, with many cycle starts or long spray runs.

Consumable parts are quickly exchanged at designated service intervals, and maintenance is easily performed in house, by the customer. The exchange of consumable gun parts does not require dismounting of the gun from the system, saving both time and preserving critical gun positioning within the spray chamber.

Environmentally Friendly

Operation of the SinplexPro 03C reduces the use of strategic resources, waste and noise pollution. SinplexPro 03C spray guns do not use thoriated tungsten components.

1 General Description

The SinplexPro 03C spray gun is explicitly designed for use in low pressure^a ChamPro systems. Because of the single cathode design, SinplexPro 03C guns can be adapted for use with most existing ChamPro spray systems and provide the excellent stability and processing reproducibility benefits of cascaded arc technology.

The SinplexPro 03C spray gun operates using argon as the single or primary gas. Hydrogen or helium can be used as secondary gases.

A standard 03CV-364-2-TF anode (functionally equivalent to the 03CP 264 and 03CP 193 anodes) is shipped with the SinplexPro 03C gun.

The powder injectors and cathode used for the SinplexPro 03C spray gun are the same as those used for the 03CP spray gun.

In addition, a variety of powder injectors, powder hoses and gun cables are available. Please see Section 3 Accessories and Options.

1.1 Cascaded Arc Control

The key benefits of the cascaded arc design employed in SinplexPro 03C series guns are:

- Higher voltage, lower amperage operation
- A magnitude of reduction in voltage oscillation
- The influence of gas flow and type on the arc length is eliminated

The cascade fixes the length of the electric arc and provides the arc with a starting path over a series of electrically neutral rings (neutrodes) within the arc chamber. Once the gun is fully ignited, only the common front nozzle is electrically connected to the power supply.

The fixed arc length stabilizes the plasma plume and eliminates the very high amplitude power oscillations inherent in plasma guns without arc stabilization. This effect is often overlooked as modern plasma controllers display filtered readings of the actual power and voltage signals from the gun. Thus, for plasma guns without arc stabilization, a plasma parameter that is displayed as 65 V may actually oscillate as much as 20 to 85 V (see section 1.4). In contrast, the stable plume produced by the SinplexPro 03C gun results in more efficient heating and a more optimized flight path of the powder particles, resulting in better coating consistency.

1.2 Built for Long Spray Campaigns

The SinplexPro 03C is designed to operate for long periods without the need to change consumable and wear parts. For many spray applications, 200 hours of operation^b can be expected before the need to change out parts such as the nozzle and cathode. The neutrode stack is expected to last for two service intervals before exchange is needed.

In addition to reducing time and cost to maintain the SinplexPro 03C, the gun will spray during this interval with little or no process degradation. This ensures highly consistent and reliable coating quality between spray gun service intervals.

^a Please note that for ChamPro systems running at ambient or slightly elevated pressure, standard SinplexPro series atmospheric plasma spray guns are recommended.

^b Service intervals stated herein are for average spray conditions and may be longer or shorter for different conditions. Customers are strongly advised to follow the inspection and service intervals stated in the product manuals until reliable service intervals are established for the customer's specific spray parameters.

1.3 Components

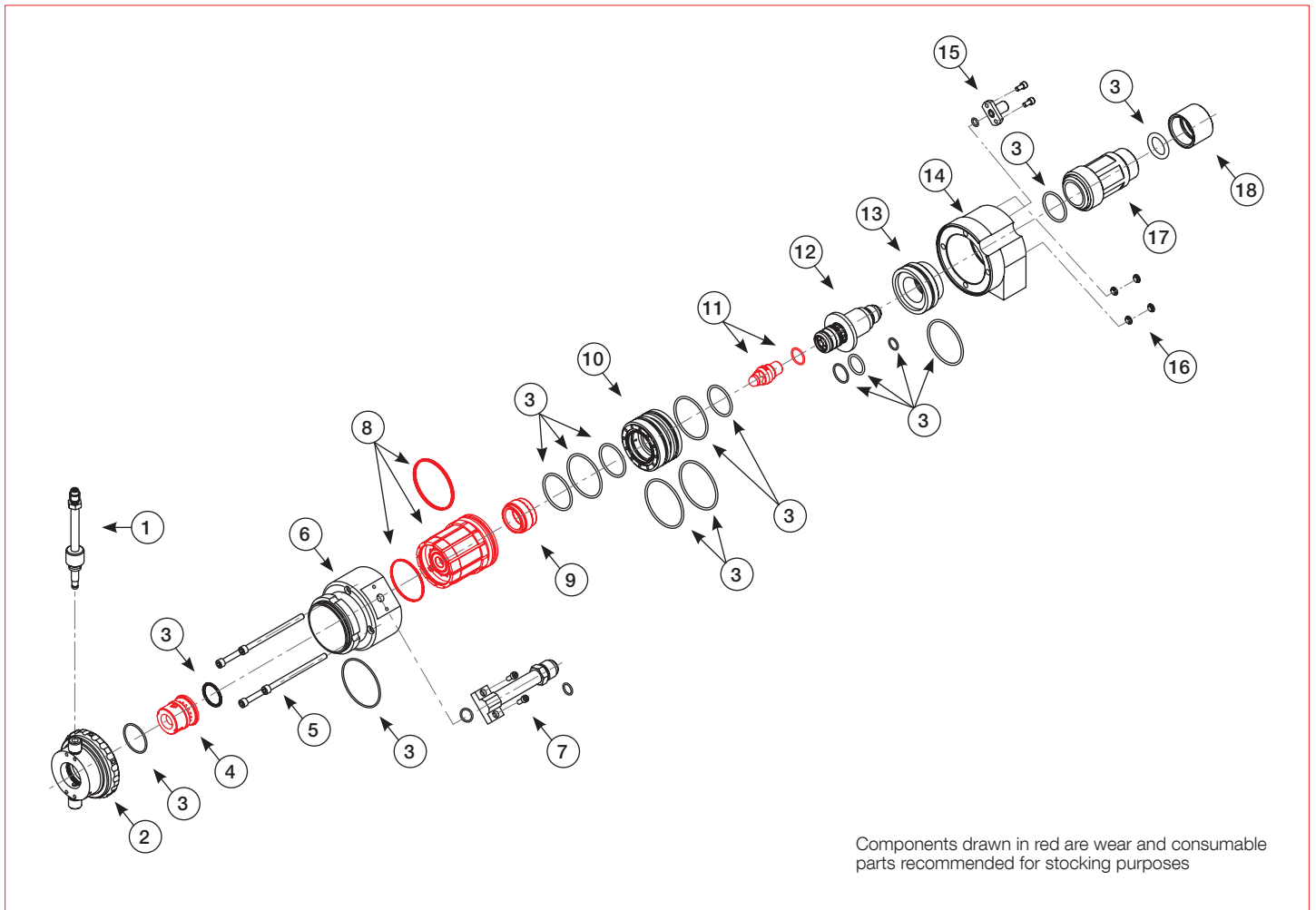

Balloon No.	Item Description
1	Powder injector straight (standard) ^a
2	Anode retainer assembly
3	O-rings (various sizes and types)
4	Anode
5	Cap screws
6	Front gun body
7	Anode extension assembly
8	Neutrode stack assembly (includes O-rings)
9	Gas ring

Balloon No.	Item Description
10	Insulator housing
11	Cathode (includes O-ring)
12	Cathode holder
13	Retaining ring
14	Rear gun body
15	Plasma gas fitting assembly
16	Closure studs
17	Negative insulator boot
18	Negative insulator nut

For complete part identification, please refer to the appropriate manual or parts list

^a See Section 3 for additional options

1.4 Voltage Stability Comparison and Power Levels

The chart to the right compares the voltage fluctuation of the cascading arc SinplexPro 03C spray gun versus the non-cascading arc 03CP spray gun. Both guns were tested using the same anode, gas mixtures (Ar/H₂) and flows.

The SinplexPro 03C spray gun exhibits little voltage variation (maximum variation of approximately 6 V), whereas the 03CP spray gun exhibits variation that is an order of magnitude higher (approximately 45 V).

Equally remarkable is the current input compared to the voltage output for each spray gun. The current input for the SinplexPro 03C spray guns is only 920 A versus that of the 03CP with a target input of 1600 A. This demonstrates the power efficiency of the SinplexPro 03C spray gun.

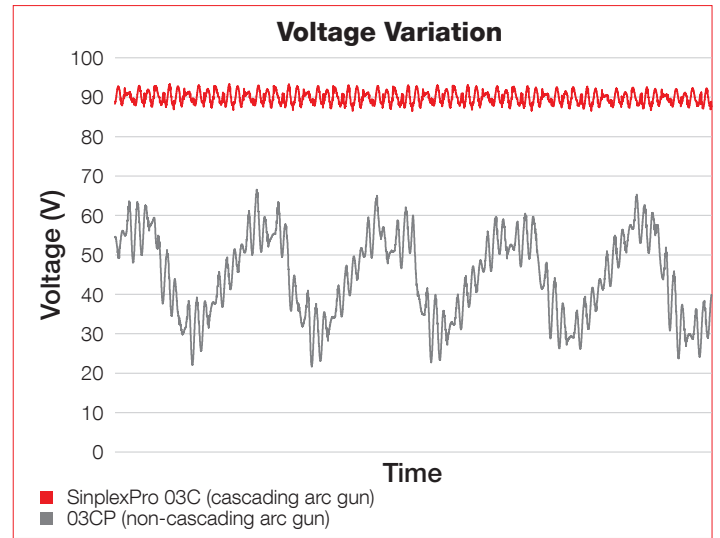

2 Features and Benefits

Effective

- Designed for low pressure plasma spray use, producing excellent coatings
- Plasma arc is stable over a wide range of gas flows, gas mixtures and pressures
- Directly replaces traditional 03C spray guns without the need for additional system hardware changes

Economical

- Reduced power input to achieve necessary net power reduces electrical costs and facility requirements
- Achieve the desired coating with significantly lower current input, thereby further reducing power consumption
- Excellent coatings can be produced with argon-only parameters, reducing the need to use expensive helium gas and improving plant safety by eliminating the need for hydrogen gas
- Low investment: integrates into existing Oerlikon Metco chambered plasma systems at minimal cost^a

Efficient

- Arc is maintained at a fixed length for constant voltage and excellent stability
- Produces the ideal plasma state for all powder particles, resulting in excellent process reliability
- Highly reproducible, SinplexPro 03C easily achieves the desired process window again and again
- Minimal process drift between gun service intervals ensures highly consistent, reliable coating quality
- Rugged and thermally robust design
- Wear and consumable parts are easily and quickly changed by the customer and can be replaced without removing the gun from the mounting fixture, saving time and preserving tool center points

Environmentally Friendly

- Quiet operation with reduced noise
- No thoriated tungsten components, eliminating a waste disposal issue

^a Review of system by Oerlikon Metco's system sales team required.

3 Accessories and Options

3.1 Powder Injectors and Adapters

Balloon No.	Item Description
1	Closing plug
2	Powder injector straight (Swagelock)
3	Powder injector 90° (Swagelock)
4	Powder injector straight (Parker) ^a
5	Powder injector 90° (Parker)
6	Powder hose heat protected (Swagelock 3 m)
7	Powder hose (Parker)

^a Standard

3.2 Water-Cooled Gun Hose Lengths

Length	Length
0.9 m (3 ft)	2.7 m (9 ft)
1.5 m (5 ft)	3.0 m (10 ft)
1.8 m (6 ft)	3.7 m (12 ft)
2.1 m (7 ft)	4.3 m (14 ft)
2.4 m (8 ft)	4.6 m (15 ft)

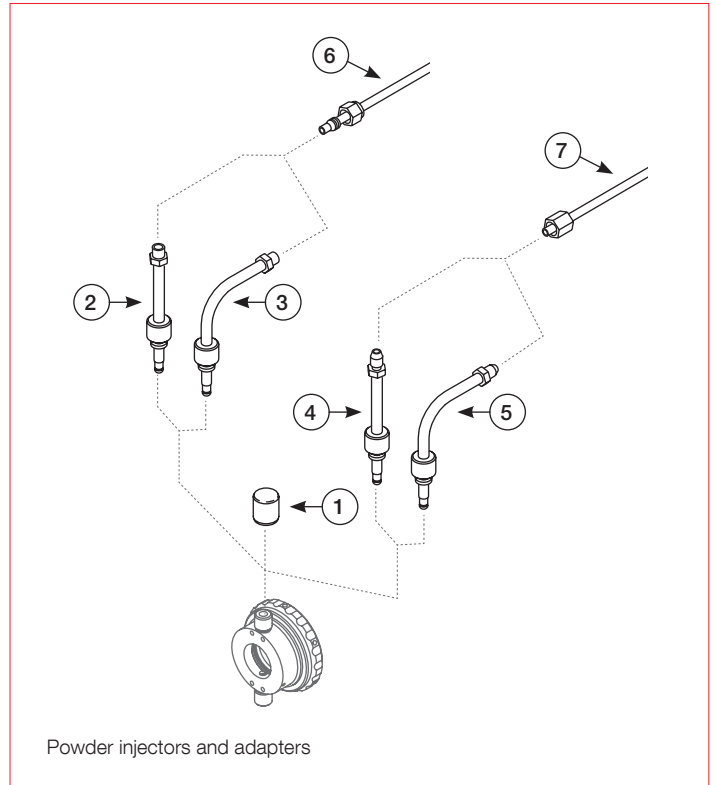

4 Technical Data

4.1 Dimensions

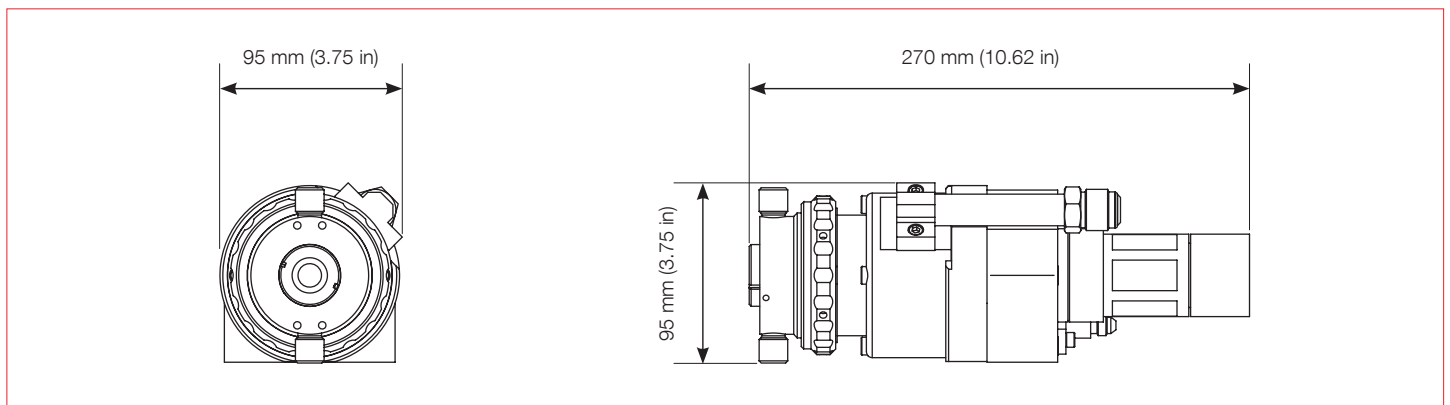

4.2 Gas Operating Limits

Primary Gas			Secondary Gas			Comments
Type	Minimum Flow	Maximum Flow	Type	Minimum Flow	Maximum Flow	
Argon	40 NLPM	130 NLPM	Nitrogen	0 NLPM	20 NLPM	Ratio >6.5:1 Ar:N2
Argon	40 NLPM	140 NLPM	Hydrogen	0 NLPM	7 NLPM	Ratio 1:20 H ₂ :Ar
Argon	35 NLPM	140 NLPM	Helium	0 NLPM	120 NLPM	> 0.4 Ar:He max (He flow ≤ 2.5 Ar flow)

4.3 Specifications

Power Rating

Maximum power – 100% duty cycle		130 kW
Maximum current	< 45 NLPM Argon	1100 A
	> 45 NLPM Argon	1200 A

Gas Quality

Argon – Ar		
Minimum requirements		99.95 %
European standard		99.998 %
Helium – He		
Minimum requirements		99.995 %
European standard		99.998 %
Hydrogen – H ₂		
Minimum requirements		99.95 %
European standard		99.998 %

Cooling Water Requirements

Inlet temperature		10 to 25 °C	50 to 77 °F
Inlet pressure		11 to 17 bar	160 to 246 psi
Outlet temperature	max.	50 °C	122 °F
Flow	min.	20 to 30 l/min	5.3 to 7.9gal/min
Conductivity	max.	< 2 µS	
Dissolved oxygen	max.	< 8 ppm	
pH	max.	6.6 to 7.0	

Weight

Without cooling jets, hoses and cables (approx.)	4.5 kg	9.7 lb
--	--------	--------

Compatibility

Controllers	MultiCoat
Powder feeder	Single 120-V, Twin 120-V, Single 220-V
Power supply	Metco PTPro 120

5 Life-Cycle Status and Support Options

Our four-phase life cycle model keeps you informed about available services and support options throughout the life span of your equipment



5.1 SimplexPro 03C Status

- Current Life Cycle Status: Active
- Inception Date: October 2020

During the Active phase, you have our full support and range of services. Using our life-cycle services will keep your equipment in the best operating condition

5.2. Keeping You Informed

We will notify you early and transparently about your options as your equipment enters into the next life-cycle phase, providing your equipment is registered with Oerlikon Metco

5.2.1. Life-Cycle Notification

Provides early information about the upcoming life-cycle phase change and how your equipment can be best supported.

5.2.2. Life-Cycle Status Statement

Provides information about the current life-cycle status and all available options and services to maintain your equipment in best condition.

5.3. The Oerlikon Metco Difference

Benefit from our selection of comprehensive services designed to ensure:

- Consistent spray quality, with little to no parameter shift
- Compliance with your ISO quality requirements
- Maximized equipment uptime
- Extended overall equipment lifetime
- Fast availability of spare parts

5.4. Your Best Value for Peak Performance

Choose from our broad portfolio of services to keep your equipment in top condition now and in the future

- Spare parts
- Preventive maintenance
- Repair Service
- Customer training

Take advantage of an Oerlikon Metco Service Agreement tailored to your specific needs!

For more information on your service and support options, please contact your Oerlikon Metco Account Manager.