

## Thermal Spray Turnkey Coating Systems

**From initial consult through startup—and beyond, Oerlikon’s turnkey system expertise is your single source for a custom-engineered package designed for production efficiency, safety and regulatory compliance.**

State-of-the-art turnkey systems are self-contained manufacturing facilities designed as individual production units for handling many different types of parts on a daily basis or fully integrated cells for mass production lines.

- Manipulation systems are custom designed for the size, geometry and daily processing requirements for your parts
- In-depth initial consult to understand your needs and budget
- Detailed quotation package and sign-off on engineering drawings
- Assembly and test at our facilities to ensure proper integration and functionality
- Fully integrated safety protocols enhance your risk management programs
- Installation supervision and start-up at your facility
- Operation and maintenance training for your staff

### Key Turnkey System Offerings

A consistent development program of process hardware and software, as well as an extensive exchange of experience with users in a wide-range of industries, has allowed us to develop a full range of customized turnkey systems that meet customer requirements.

- Core thermal spray technology
- Single and multiple process systems
- Control and management systems
- Integrated robotic handling systems in a variety of high-level problem-solving designs
- Work stations designed for highly efficient production
- Customized handling designs for demanding and highly technical applications

The turnkey systems shown here are an exemplary illustration of Oerlikon Metco’s comprehensive capabilities in industrial engineering and design.

### Cylinder Bore Coating System

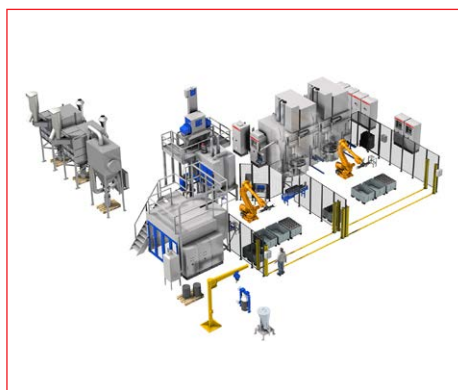

This highly standardized production system applies a plasma-sprayed coating directly into engine block cylinder bores while automating the complete coating process.

#### The Solution

The installation accommodates the coating process of cylinder bores for diesel truck engines. Through efficient automation and process control, the cylinder bores are cleaned, surface roughened, coated with plasma spray, cooled and tagged. The system employs robotically-controlled automation for part handling using a pick-and-place operational mode. Our unique Rotaplasma™ HS1 gun manipulation system rotates the gun within the cylinder bore while allowing the asymmetrical engine block to remain stationary.

### Coating System for Transition Ducts

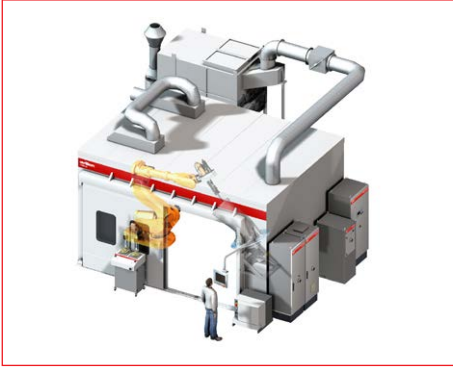

In conventional spraying, the bulky transition duct is rotated or indexed while the plasma gun is moved axially through the transition duct. Our more efficient solution rotates the plasma spray gun while keeping the workpiece stationary.

#### The Solution

The system employs a plasma spray extension gun mounted on a rotating gun manipulator and its motion is programmed to follow the variable cross-sectional profile of the fixtured transition duct. This results in a more homogeneous coating microstructure and thickness throughout the transition duct and a superior service life.

### Multi-Process Thermal Spray Coating System



An innovative thermal spray installation for coating large, heavy industrial rollers that features four processes in one system: atmospheric plasma spray, liquid-fuel HVOF, electric arc wire and post-coat sealing.

#### The Solution

The parameter programming and monitoring for all four processes is handled through a master control unit. A rotating, dual workpiece handling station allows one roller to be loaded or unloaded while a second roller is coated, thus saving time and cost through continuous processing.

### Coating System with Indexing Turntable

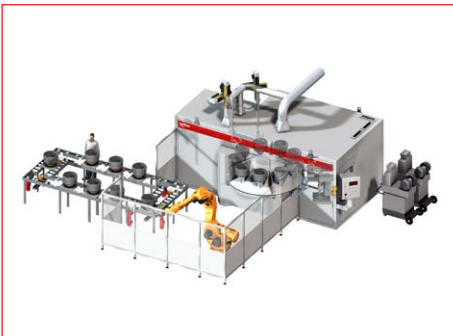

This system is highly automated for top performance. It ensures a continuous flow of parts that is perfect for mass production operations.

#### The Solution

This fully automated system concept features a robotically controlled part manipulator and an indexing turntable. Parts are cycled through an automated loading / unloading station and picked and placed on the turntable externally to the spray cabin. The turntable indexes the parts into the spray cabin where the coating is applied. After coating, the parts index out of the spray booth where they can go on to their next processing step.

## Ready to get more out of your thermal spray system?

Talk to your Oerlikon Metco Account Representative today!

Information is subject to change without prior notice.

FLY-0030.2 – Thermal Spray Turnkey Systems  
© 2018 Oerlikon Metco

**oerlikon**  
metco

[www.oerlikon.com/metco](http://www.oerlikon.com/metco)  
[info.metco@oerlikon.com](mailto:info.metco@oerlikon.com)