

# Article 3: Masking – Superhero or Villain?

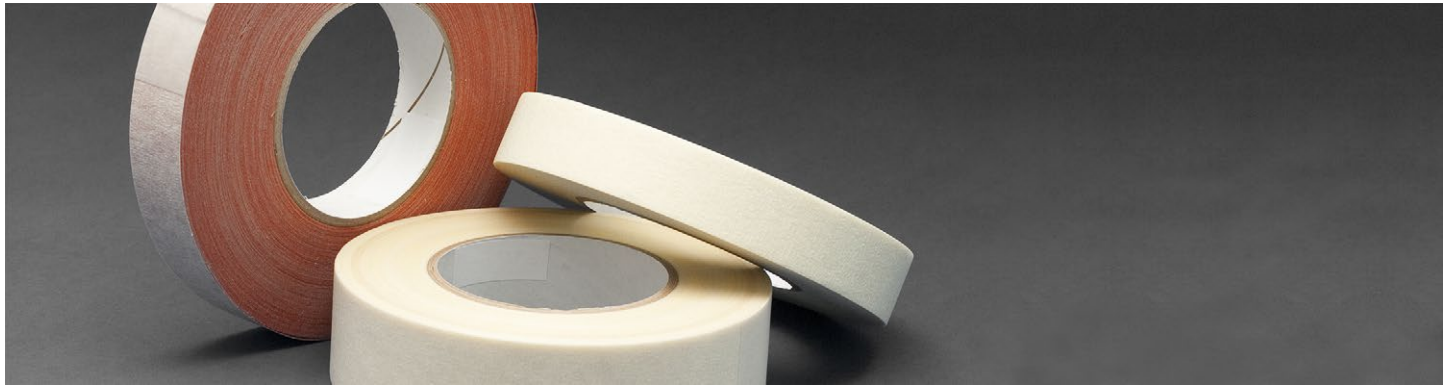

by Steve Bomford  
Training and Application Support Manager

Well, here we are at my third article! Continuing with the same theme and moving onward with my progression through the thermal spray process, I am going to put my thoughts towards masking.

## Why We Need to Mask

So far, we've discussed subjects that include overviews of some of the available thermal spray processes, together with the preparation needed to create an adherent coating.

Another aspect of preparation is the “necessary evil” that is masking. Masking is employed as a protection process required to prevent damage to the part being coated both from surface roughening prior to coating and from the deposition process itself. Effectively, it is used as a method of preventing a coating being deposited where you don't want it (or the customer won't allow it).

To a certain extent, it is a non-added value process. You spend all this money on buying and applying masking tape, masking compounds, lacquers etc. only to peel them off and drop them in the trash when you are finished (masking is not that environmentally friendly a process). However, without masking we could not:

- Precisely define the location of where we want the coating
- Protect vulnerable parts of the component
- Prevent build-up of lower quality deposits in turbulent areas
- Reduce notch sensitivity at coating transition points

So, with these in mind, as well as other points we will discuss within this article, we really need to consider if masking should be kept anonymous or be more widely recognized for its heroic abilities...

## Choosing the Right Masking for the Job

When thermal spraying, the first thought is often to turn to masking tape. This might be a suitable choice, but even then, which one? Masking can have a significant cost impact on the thermal spray process as a whole and therefore ideally it should be used as efficiently as possible.

Tape masking is a (literally) flexible option, but other choices are available. The decision often depends on factors including:

- Process energy levels - Thermal and kinetic energy transfer from the flame and particle impingement.
- Part geometry - Conformability to the part being coated.
- Accuracy of coating location - Masking placement and reduction of “bridging” effects (more later)

So, let's go with tape as a starting choice. If we pick the right tape for the job, we can mask just once to cover both grit blasting and spraying procedures. In Figure 1, we

can see that although the tape apparently stood up to the blasting process, it was less than suitable for protecting the part during spraying.

In this instance, we have come across a common problem where that elusive “golden nugget”, masking tape that can stand up to the aggressive energies of the HVOF (High Velocity Oxygen Fuel) process was not found. There are tapes in the marketplace purporting to work in this environment, but it is certainly open to debate how well they work in every instance.

## The Taping Process

Thermal spray masking tapes are typically constructed from a combination of silicone



Figure 1: Masking tape spray test.

rubber, woven fiberglass, metal foils, and a silicone adhesive.

In order to ensure satisfactory adhesion, these materials must be smoothed and pressed down strongly to create a good bond of the masking tape to the component surface. There is nothing worse than having spent hours setting up your job, only to see the masking tape gradually peel off during spraying. At what point do you abandon hope and stop? Figure 2 shows a gas turbine component which is in the process of being masked. The level of effort employed to produce a good bond can be seen by the surface markings on the tape (please avoid using the handle of a scalpel to do this!)

In Figure 3 we can see the effects of poorly placed or detached masking. The coating is effectively "shadowed" while it is being deposited. This therefore creates a deposit area of thin or poor quality. This often means that the part will have to be re-worked (this can be both a costly and technically demanding issue).

Shadowing can be used as a positive technique for masking. While it is possible to shadow using tape, metal masking is by far the best promoter of this method (more on this subject later).

### Getting the Best Out of Tape Masking

We have already mentioned some instances where tape masking can go wrong. As well as rubbing down the tape with all of our might, there are other procedures that are worth considering to improve our level of success. Figure 4 shows a TBC (Thermal Barrier Coating) on a gas turbine nozzle.

In this case, when the component was initially masked, 2 layers of tape were applied. Subsequently, during the spraying operation, the outer layer of tape has been burnt away, leaving the inner layer still in position. The application of a dual layer has therefore protected the part from overspray.

Tape supply companies can provide tape which is already "double-layered". My personal preference is to apply one layer on top of the other as the random overlaps tend to improve the overall bond of the masking system.

Another important point of note shown in Figure 4 is the build-up of ceramic coating on the tape. The masking has done its job in protecting the part, but great care must be applied when removing it in order to ensure that the brittle coating is not chipped

or debonded. The common practice for removing all masking tapes is therefore to ensure the direction of removal is away from the applied deposit.

In this particular application, consideration can also be given to applying a line of weakness at the tape/coating interface using a tool such as a scalpel (care must be taken not to cause more harm than good). This method will introduce a preferential failure zone which can reduce coating chipping effects.

### It's Not All About Tape!

Of course, as already mentioned, tape is not the only solution. As applications get more challenging and geometry of parts become more of an issue, application of lacquers and other liquid maskants can become a useful option. Just be aware that they will perform differently.

Advantages include a more conforming mask that interferes less with the spray stream. Disadvantages can include a masking material that will withstand spraying, but not grit-blasting (there are some notable exceptions to this statement). These masking materials are chosen based on the suitability for the application at hand, so common rules of use are difficult to define.

Here we see one of the exceptions to the norm, where the applied masking material stands up well to both blasting and spraying.

As we move forward in the development of positional sensing technology, it is not beyond the realms of imagination to perceive a time when very arduous masking processes can be aided by automation (Figure 5). For example, protection of cooling holes on blade repairs requires significant time and patience as the holes can vary in size and position dependent on the condition of the blade. An enhanced or fully automated

sealing process could improve quality and reduce costs.

### Testing Your Metal!

Heading towards the less flexible side of masking, we start to enter a different, more shadowy world...



Figure 2: Tape masking for Air Plasma Spray (APS).



Figure 3: "Shadowed" APS molybdenum-based deposit.



Figure 4: Multi-layer taping methods..

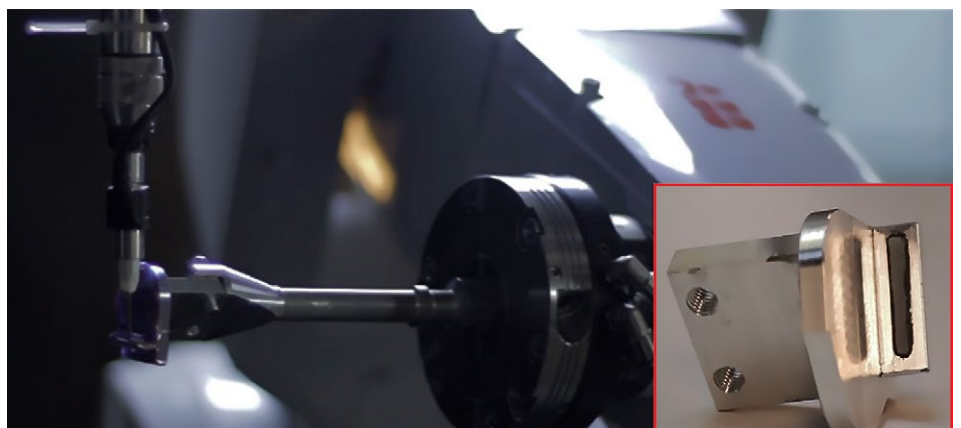

Figure 5: Robotic application of UV curing resin together with finish sprayed test component.

The use of metal masking can be enormously useful when we need to produce very accurate delineations between masked and unmasked surfaces. Also, when using very energetic deposition techniques such as HVOF or Chamber processes (e.g., Vacuum Plasma Spray), then metallic masking is normally the only way to go.

Figure 6 shows the basic shadowing principle which is often (but not exclusively) utilized with metal masks. Here you can see that positioning the mask above the surface of the area to be coated will produce a smooth transition between coating and substrate. This has the advantage of reducing stress concentration and therefore improves local adhesion of the deposit and reduces notch sensitivity effects. Lack of direct contact between the active mask and the part being coated also reduces possible "bridging" of the deposit and therefore subsequent chipping effects.

The cost of the manufacture of metal masking can be viewed as somewhat prohibitive, but this has to be balanced against the necessities of the application, as well as the potential gains it can provide. For example, Figure 7 shows how this type of masking can be used to prevent the negative effects of turbulence and bounce off adjacent vertical surfaces. Effectively, the mask is removing the potentially poor coating from the equation as well as providing an accurate coating position.

If cost is your concern, then don't forget what the humble nut and bolt can do for you. Many a hole has been plugged up in this way. Don't forget that the use of a properly sourced bolt will also give the added advantage of a shadow mask so that really professional job can be delivered to the customer (see Figure 8). At the end of the day, that's what masking is really all about!

**In Conclusion...**

Masking is an integral part of the thermal spray process and should be treated as such. Care must be taken over the specifi-

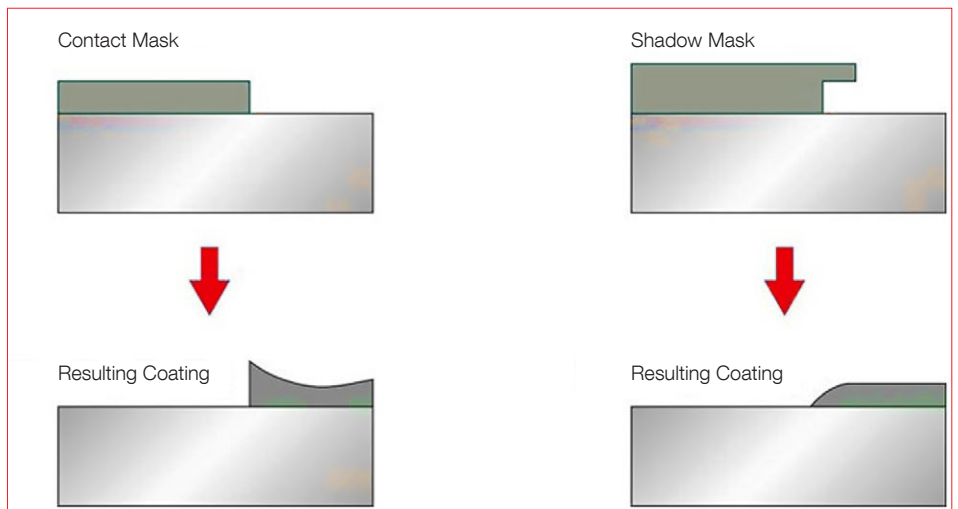

Figure 6: Contact versus "Shadow" masking techniques.

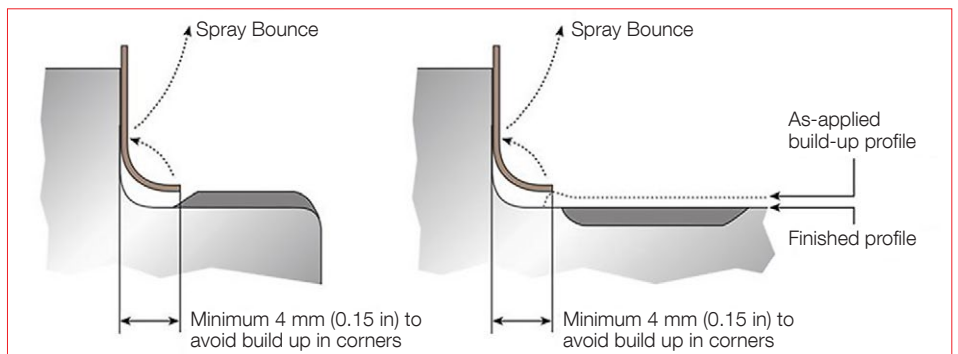

Figure 7: Reducing "Spray Bounce" effects using shadow masking.

cation of the masking materials used, their placement on the part being sprayed, the design of the masking technique with respect to the relevant spray process and last, but not least, its final removal (ensuring that our precious coating is not damaged near the very end of a costly process).

Spraying is a dynamic process. Although we have reviewed some of the basic masking methods, there are always new techniques to be learned and optimized in order to protect the component effectively.

One thing is for sure, without masking, we would not have a satisfactorily surface engineered product. So, I guess masking is a

little bit of a Superhero after all!

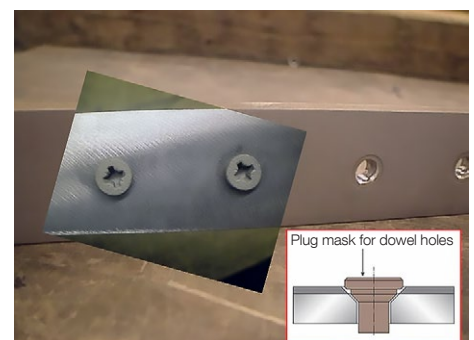

Figure 8: Plug masking for HVOF coating application.

## **A Note From the Author**

Dear Friends and Colleagues,

In my third article, I hope to provide an overview of those masking procedures required to make sure that our valuable coating ends where it needs to be and prevents it sticking where it shouldn't (this type of deposit always seems to be the best adhered for some reason!).

A look at different masking techniques as well as the provision of some hints and tips will hopefully be of interest. As usual, I ask you to excuse me for not covering everything, but masking is another one of those large subjects in which many people have significant knowledge and also differing opinions.

As usual I would like to invite you to join me in the discussions, ask questions, and leave your personal opinion. Also, if there is a related topic you want me to write an overview of, I will be happy to consider that (thanks for the suggestions already received). I hope it will be interesting to read and will be happy to receive your feedback.

All images used herein are agreed with content providers, taken from open access Internet sources or are the property of Oerlikon Metco.

## **About Oerlikon Surface Solutions Division**

Oerlikon is a leading global provider of surface and additive manufacturing solutions and services. The division offers an extensive portfolio of market-leading thin-film, thermal spray and additive manufacturing technologies, equipment, components and materials. Emission reduction in transportation, maximized longevity and performance of tools and components, increased efficiency and intelligent materials are hallmarks of its leadership. Pioneering technology for decades, the division serves customers with standardized and customized solutions across a worldwide network of more than 170 sites in 37 countries.

With its technology brands – Oerlikon Balzers, Oerlikon Metco and Oerlikon AM – Oerlikon's Surface Solutions division focuses on technologies and services that improve and maximize performance, function, design, reliability and sustainability, which are innovative, game-changing advantages for customers in the automotive, aviation, tooling, general industries, luxury, medical, semiconductors, power generation and oil & gas markets.

The division is part of the publicly listed Oerlikon Group, headquartered in Switzerland, which has 12 000 employees and generated CHF 2.65 billion in revenue in 2021.

Information is subject to change without prior notice.